

**Minutes of the 23rd Meeting of
North District Council (2012-2015)**

Date : 30 July 2015
Time : 9:30 am to 1:25 pm
Venue : Conference Room of the North District Council

Present

Chairman:

Mr SO Sai-chi, SBS, MH*

Members:

Mr HAU Kam-lam, MH, JP*

Mr TANG Kun-nin, Tony, MH*

Mr YIP Yiu-shing, Chris, MH (9:30 am – 12:05 pm)

Mr WONG Wang-to*

Mr LARM Wai-leung*

Mr LAU Kwok-fan, MH (9:30 am – 11:53 am)

Mr WONG Yun-keung, Simon*

Mr LEE Koon-hung (9:47 am – 11:53 am)

Mr LI Kwok-fung (9:30 am – 11:53 am)

Ms LAM Lai-fong, Fanny*

Mr HAU Chi-keung (9:30 am – 11:53 am)

Mr YIU Ming*

Ms OR Sin-yi, Windy*

Mr CHAN Yung, BBS, JP*

Mr CHAN Shung-fai (9:44 am – 12:17 pm)

Mr PANG Chun-sing, George, MH (9:49 am – 1:25 pm)

Mr TSANG King-chung, Kent (9:38 am – 1:25 pm)

Mr WAN Wo-tat, Warwick*

Mr WAN Wo-fai, MH*

Mr LIU Kwok-wah*

Mr LAI Sum*

Mr LAW Sai-yan (9:30 am – 1:07 pm)

Mr TAM Kin-keung, Terry (9:36 am – 1:25 pm)

Secretary:

Ms CHU Wai-lin, Francoise

Senior Executive Officer (District Council), North District Office

Remarks: * Members who attended the whole meeting

() Time of attendance of Members

In Attendance

| | |
|---------------------------|---|
| Mr YAU Kin-chung, JP | District Officer (North), Home Affairs Department |
| Mr TUNG Joseph | District Commander (Border), Hong Kong Police Force |
| Ms LAU Fung-ha | Acting District Commander (Tai Po), Hong Kong Police Force |
| Mr TAM Chung-keung | Chief Engineer/New Territories East 3, Civil Engineering and Development Department |
| Mrs CHIU TSE Shuk-yin | Senior Housing Manager/Tai Po and North, Housing Department |
| Mr TANG Fei-lit, Philip | District Social Welfare Officer (Tai Po/North), Social Welfare Department |
| Ms HO Suet-leung, Stella | Acting District Lands Officer (North), Lands Department |
| Mr LO Ka-kan, Gregory | Acting Chief Transport Officer (New Territories East), Transport Department |
| Ms OR Wai-yee, Wendy | Chief Leisure Manager (New Territories North), Leisure and Cultural Services Department |
| Mr NG Wai-keung | Chief Health Inspector 2, North District, Food and Environmental Hygiene Department |
| Ms KWONG Ting-lok, Maggie | Assistant District Officer (North) 1, Home Affairs Department |
| Mr SO Chun-kit, Herman | Assistant District Officer (North) 2, Home Affairs Department |

Item 2

| | |
|----------------------------|--|
| Mr CHAN Chun-fung, Michael | Principal Assistant Secretary (Planning & Lands) 5, Development Bureau |
|----------------------------|--|

| | |
|-------------------------|---|
| Mr IP Wing-cheung, Alan | Deputy Project Manager (New Territories East) 2, Civil Engineering and Development Department |
| Mr LAW Man-tim | Chief Engineer/New Territories East 4, Civil Engineering and Development Department |
| Ms NG Suet-ye, Joyce | Chief Estate Surveyor (Acquisition Section), Lands Department |
| Ms CHIN Man-yi, Maggie | District Planning Officer/Fanling, Sheung Shui and Yuen Long East, Planning Department |
| Mr LAI Yee-yan, Stephen | Project Manager, AECOM |

Item 3

| | |
|--------------------|--|
| Mr HUI Siu-wai, JP | Director of Buildings, Buildings Department |
| Mr YIP Wing-chung | Senior Structural Engineer/C5, Existing Buildings Division 1, Buildings Department |
| Ms NG Ka-yin | Administrative Assistant to the Director of Buildings |

Opening Remarks

The Chairman reminded persons attending and observing the meeting that according to Section 15(2) of the North District Council Standing Orders (NDCSO), if a person attending or observing a meeting of the Council acted in such a way as to disrupt the orderly conduct of business of the meeting, the Chairman might issue warnings to the person. The Chairman might order the person to leave the place of the meeting if the person persisted with such acts despite warnings.

2. The Chairman welcomed Members and representatives of government departments to the 23rd NDC meeting, in particular, the three departmental representatives who attended the meeting for the first time, namely, Mr LO Ka-kan, Gregory, Acting Chief Transport Officer (New Territories East), Transport Department, Mr NG Wai-keung, Chief Health Inspector 2, North District, Food and Environmental Hygiene Department, and Mrs CHIU TSE Shuk-yin, Senior Housing Manager/Tai Po and North,

Housing Department (HD).

Item 1: Confirmation of Minutes of the Last Meeting

3. The Council confirmed the minutes of the 22nd meeting held on 11 June 2015.

Item 2: Kwu Tung North and Fanling North New Development Areas, Road and Sewerage Works under Advance and First Stage Works and Site Formation Works for the Building of the Residential Care Homes for the Elderly

(NDC Paper No. 41/2015)

4. The Chairman, on behalf of NDC, welcomed Mr CHAN Chun-fung, Michael, Principal Assistant Secretary (Planning & Lands) 5, Development Bureau (DEVB), Mr IP Wing-cheung, Deputy Project Manager (New Territories East) 2, Civil Engineering and Development Department (CEDD), Mr LAW Man Tim, Chief Engineer/New Territories East 4, CEDD, Ms NG Suet-ye, Joyce, Chief Estate Surveyor (Acquisition Section), Lands Department (LandsD), Ms CHIN Man-yi, Maggie, District Planning Officer/Fanling, Sheung Shui and Yuen Long East, Planning Department (PlanD) and Mr LAI Yee-yan, Stephen, Project Manager, AECOM.

5. Mr CHAN Chun-fung, Michael introduced the road and sewerage works under the advance and first stage works of Kwu Tung North (KTN) and Fanling North (FLN) New Development Areas (NDAs) as well as the site formation works for the building of the residential care homes for the elderly (RCHEs). The main points were as follows:

- (a) This consultation was mainly about the road and sewerage works under the advance and first stage works of KTN and FLN NDAs as well as the site formation works for the RCHEs building, i.e. part of the advance preparation work for NDAs to facilitate the gazette of the above works by CEDD later this year;

- (b) after obtaining the approval of the Finance Committee of the Legislative Council (LegCo) for the funding application last year, CEDD commenced the detailed design and site investigation for the advance site formation and engineering infrastructure works for the two NDAs at the end of last year. At present, CEDD was carrying out work related to the implementation of the NDAs project, including the gazette of the road and sewage works at the end of this year, and land resumption and site formation works for the new RCHEs building for proper rehousing of the elderly residents of the Home for the Elderly at Shek Tsai Leng (hereafter referred to as “STL Home”);
- (c) the Government hoped that CEDD could commence the site formation works of the new RCHEs building next year so that the construction works could be commenced afterwards in order to minimise the effect of removal in future on existing elderly residents of RCHEs. In order to commence the construction of the above building as soon as possible, the Government had to resume the land of the lot concerned. After studying, DEVB and the Labour and Welfare Bureau prepared to construct a new RCHEs building with 1 100 residential care places for the elderly in the vicinity of the present STL Home, which could rehouse all eligible elderly residents affected by the clearance exercise;
- (d) the Government announced the NDAs project in 2013. KTN and FLN NDAs were future sources of land and housing supply of Hong Kong. It was anticipated that upon completion of the NDAs project, a total of 60 000 housing units would be supplied with about 60% of which being public housing (PH) and Home Ownership Scheme (HOS) units;
- (e) after a 45-day hearing, the Town Planning Board submitted the draft KTN and FLN Outline Zoning Plans (OZPs) for examination of the Executive Council this May, and the Chief Executive in Council approved the draft OZPs this June. That meant the implementation of the NDAs project had entered a new stage. If everything proceeded smoothly as originally planned and the funding applications were approved by the LegCo, land

resumption work would be carried out in due course and the major works would commence in 2018. The first batch of residents would move into the NDAs in 2023 at the earliest; and

- (f) the Government fully understood views of residents and occupants affected by the NDAs project on compensation and rehousing proposals, in particular, the appeal for “rehousing in situ” by villagers. In the past, the Government unceasingly explored better rehousing arrangements in order to meet the rehousing needs of villagers properly. Although no concrete proposals were available for consideration of various parties for the time being, the Government would continue to listen to and carefully consider views of residents and the community so that the rehousing arrangements suited and met the needs of residents. In the meantime, the Government introduced the Special Ex-gratia Compensation proposal to assist affected residents in their removal. He reiterated the Government would ensure that affected residents obtained the protection provided by prevailing laws and policies before carrying out the clearance exercise. Apart from affected residents, the Government wished to maintain communication with stakeholders affected by the NDAs project such as the Home of Loving Faithfulness, farmers, factory owners and shop operators. The Government would explore how to provide assistance and formulate proposals that met the needs of various stakeholders in terms of policy or on merit of individual cases for consideration of various parties, in particular, factory owners and farmers who wished to continue business operation and farming.

(Mr TAM Kin-keung, Terry and Mr TSANG King-chung, Kent joined the meeting at this juncture.)

6. Mr IP Wing-cheung presented NDC Paper No. 41/2015 by PowerPoint. The PowerPoint slides were at Annex I.

(Mr CHAN Shung-fai, Mr LEE Koon-hung and Mr PANG Chun-sing, George joined the meeting at this juncture.)

7. The Chairman asked observers to comply with the requirement of

Section 15(2) of NDCSO by keeping silent to facilitate the proceeding of the meeting. As the advice went unheeded, the Chairman warned those observers who breached the regulation, and reminded them that the security guards on site would lead those observers who disrupted the orderly conduct of business of the meeting to leave the place of the meeting.

8. Mr LAU Kwok-fan put forward the following questions and views:

- (a) He asked about the time table of the road network works at Shek Tsai Leng. Since ten RCHEs blocks would be affected by the L1 road works, he hoped that the implementation of the works could be delayed to tie in with the “seamless transition” arrangements for the old and new RCHEs so that RCHEs residents or their families would not be affected by the removal. As far as he knew, the operator of STL Home and associated stakeholders did not oppose the NDAs project and what they concerned most was the proper rehousing of affected RCHEs residents. He hoped that the Government could improve the “rehouse first, develop later” arrangements in the advance works of the NDAs project;
- (b) the road network works at FLN would block the entrances of the nearby squatter villages and affect the living of the villagers, in particular, the elderly or people with impaired mobility. The departments concerned should assist in solving the problem;
- (c) since the Government did not announce the timetable for land resumption, it was difficult for squatter villagers to decide whether to carry out repairs works to their squatter huts, thus affecting their living. He had suggested that government departments should consider arranging a “freezing survey” during the consultation session in order to protect the interests of land owners, villagers and the Government. Although government departments accepted his suggestion, he later found out that residents registered at the “freezing survey” might not enjoy the same rights as those who registered just before the clearance exercise after land resumption was confirmed. He considered this arrangement unfair to the former and was not conformed to his original

intention in respect of the “freezing survey”. He hoped that DEVB could explain at this meeting whether the “freezing survey” would be treated the same as the pre-clearance survey in order to protect the interests of squatter villagers; and

- (d) in respect of resumption of private lands in the NDAs project, he asked why affected residents were only allowed to receive cash compensation from developers but not offered the option of “rehousing to PH”. Some residents wished that they could choose between cash compensation and “rehousing to PH”, and they also wished that those eligible for “rehousing to PH” could be exempted from the means test.

9. Mr LAW Sai-yan put forward the following questions and views:

- (a) The government departments concerned had not responded to appeals such as “no removal and no demolition” and “harmony between the city and the countryside”, and implemented the NDAs project even when details in respect of actual compensation, “exemption of the means test”, “rehousing in situ” and the agriculture policy, etc. were unavailable so that some affected villagers were very dissatisfied. Before the formulation and implementation of the NDAs project, the Government should positively consider views and suggestions put forward by various sectors of the society and give priority to solving existing problems so that different stakeholders could participate in and benefit from the NDAs project;
- (b) he considered that government departments should first properly rehouse the affected residents of STL Home through “seamless transition”; and
- (c) he was concerned whether the present road planning for NDAs could cope with the increased traffic flow upon completion of NDAs in future.

10. Mr LIU Kwok-wah put forward the following questions and views:

- (a) In view of problems and effects on nearby residents brought by sewage treatment works and that at present sewage treatment works were already provided in the vicinity of Sheung Shui Wai, he strongly opposed the construction of sewage treatment works at the said location. He hoped that government departments concerned could reach a consensus with local residents on this matter before considering the construction plan of sewage treatment works; and
- (b) he suggested that the Government should include the whole Tin Ping Shan Tsuen into the scope of NDAs, and hoped that the Government could offer affected villagers arrangements such as cash compensation, rehousing in situ, “rehousing to PH” or rebuilding of villages. The Government should also consider delaying implementation of the advance works so that villagers of Tin Ping Shan Tsuen would not be affected by the works;

(Since the conduct of some observers disrupted the orderly proceeding of the meeting despite repeated warnings, the Chairman announced the suspension of the meeting for 10 minutes and asked the security guards on site to lead those observers who breached the regulation to leave the place of the meeting. The meeting resumed afterwards.)

- (c) he hoped that the NDAs project could retain the whole Fu Tei Au Village which had conservation value, and cancel the plan of building “police driving and transport training” and “weapon training” facilities at Fu Tei Au so that the daily living of villagers would not be affected by noises created by these facilities; and
- (d) he suggested that residents affected by the NDAs project should be exempted from the means test and rehoused to PH.

11. Mr WONG Wang-to put forward the following questions and views:

- (a) He supported the offer of “rehousing in situ” arrangements for residents affected by the NDAs project, and considered that

residents should be exempted from the means test and rehoused to PH;

- (b) he asked CEDD to explain clearly the timetable for the L1 road works at Shek Tsai Leng in the NDAs project, whether the works would tie in with the “seamless transition” arrangements for the old and new RCHEs, and the scope of the drainage works at Shek Tsai Leng and the effect of the works on residents of RCHEs, in particular Blocks 1 and 2 of RCHEs. He hoped that the Government could minimise the effect of the works on RCHEs residents and implement “seamless transition” of RCHEs in order to remove their worries. He considered that it would be the best arrangement if the works commenced only after the transition between the old and new RCHEs was completed; and
- (c) he hoped that a platform for regular communication and exchange of information, in particular in respect of the development of Shek Tsai Leng, between government departments concerned and affected residents could be provided.

12. Mr HAU Chi-keung put forward the following questions and views:

- (a) He understood that stakeholders of various sectors of the society had different views on the NDAs project. Taking new town development in Hong Kong in the past as an example, if the Government provided reasonable compensation according to the change of economic environment and needs of various sectors, most villagers would choose to move out so that land could be vacated to tie in with plans of land and housing supply in Hong Kong, or even the overall development of Hong Kong in future. He, therefore, considered that the Government should provide more specific information for affected people in respect of issues such as compensation, land resumption or removal. Although the rural committees in North District supported the NDAs project, the Government had to consider the interests of residents and, based on the precedent of “taking special measures for special problems”, to consider carefully and make an effort to carry out land

resumption and compensation according to the needs and interests of affected residents so that the livelihood issues caused by the NDAs project could be handled properly; and

- (b) he opposed that residents affected by the NDAs project had to be subject to the means test before being rehoused to PH.

13. Mr LARM Wai-leung put forward the following questions and views:

- (a) Residents of KTN had all along been concerned that the planning and development of the area would affect their living because they did not obtain sufficient information of the NDAs project. As far as the details of the NDAs project provided at this meeting were concerned, the government departments concerned still did not fully respond to appeals of affected residents, resulting in a divergence of opinions;
- (b) he was concerned about how government departments concerned would properly rehouse villagers of the KTN Village affected by the works and respond to their eight appeals. He hoped that all stakeholders would be rational and impartial during discussion of the NDAs project and the Government should listen and actively deal with their appeals; and
- (c) he asked whether Mr LAW Sai-yan supported the NDAs project.

14. Mr TANG Kun-nin, Tony stated that he understood the present demand of Hong Kong society for housing supply and the worry of affected residents on rehousing. In this respect, he hoped that government departments concerned would co-ordinate with each other in the implementation of the NDAs project and fully consider how to properly handle appeals of affected residents such as compensation, “rehousing in situ” or “exemption from the means test” in order to achieve the embodiment of “always people first”.

15. Mr HAU Kam-lam put forward the following questions and views:

- (a) The NDAs project had been introduced for many years but the Government still did not announce the compensation proposals causing the affected residents doubtful of whether the Government would respond to their appeals and creating dissatisfaction. He hoped that the Government would listen to the appeals of affected residents by offering them suitable and lenient arrangements, and announce the details of compensation proposals at the end of this year or in the first quarter of next year at the latest so that residents could arrange and plan for their future;
- (b) he considered that the Government should pay attention to the appeal of KTN residents for rebuilding Kwu Tung Village and discussed with them about the feasible proposals. Besides, he considered that affected residents who accepted the offer of “rehousing to PH” should be exempted from the means test. The Government should also grant ex-gratia payments to all residents affected by the clearance exercise to meet expenses on moving to their new homes;
- (c) he agreed that the Government should assist business operators, schools or farmers affected by the NDAs project in resuming their businesses after completion of the NDAs project, and considered that would help employment of residents and stability of society;
- (d) he was concerned about the effect of the L1 road works at Shek Tsai Leng on RCHEs and their environment, and considered the Government should as far as possible commence the works only after affected RCHEs residents were rehoused to the new RCHEs. Besides, he considered that the Government had listened to views of stakeholders of RCHEs in respect of “seamless transition”, and discussion between them and government departments concerned on details of implementation of “seamless transition” was now pending; and
- (e) he hoped that the NDAs project could achieve the objective of “sharing the results of development”.

16. Mr LAW Sai-yan supplemented that since the Government did not

inform residents of STL Home and their families that they could move together as a group, they were concerned that residents would be arranged to move to different RCHEs throughout the territory. Therefore, “seamless transition” was very important. He considered that works for RCHEs and its surrounding should commence only after details of “seamless transition” were confirmed.

17. Mr TSANG King-chung, Kent stated that he did not object to development and hoped that residents of North District also did not object to development. He pointed out that most of the existing housing units occupied by residents of North District came from past development projects and were attributed to sacrifices made by affected residents to vacate land for development in the past. He believed that the “seamless transition” proposal put forward by the Government could benefit all affected persons including RCHEs residents. However, he was concerned whether the proposal was just a slogan or would be actually implemented. At present, RCHEs were concerned about how the proposal would be implemented, reflecting that consultation in respect of “seamless transition” arranged by the Government was insufficient. He hoped the Government could provide more information to affected residents before commencement of the advance works in order to remove doubts of residents about the NDAs project and minimise objections so that the project could implement smoothly and members of the public on the waiting list of PH could be allocated PH flats quickly.

18. Mr WAN Wo-tat, Warwick considered that the Government only focused on planning in the discussion of the NDAs project on various occasions and did not provide positive and proper answers to enquiries of affected persons, in particular, details of “seamless transition” so that various affected stakeholders including the operator of the STL Home, affected farmers or business operators were confused and were unable to decide whether to invest more in their businesses. He hoped that the Government could provide a platform for better communication with various stakeholders of the NDAs project for carrying out thorough discussion on rehousing and compensation problems in order to reach a consensus so that the NDAs project could be carried out smoothly, helping to solve the problem of short housing supply.

19. Mr YIP Yiu-shing, Chris put forward the following views:
- (a) He agreed that “seamless transition” was very important in proper rehousing of RCHEs residents, and hoped that government departments concerned could adjust the works schedule accordingly to tie in with the “seamless transition” arrangements and commence the works only after residents of STL Home were properly rehoused. He considered such arrangement could reduce worries and objections of some people to the NDAs project; and
 - (b) different stakeholders of KTN had different views on matters related to compensation and rehousing. Since the Government had set a bad precedent by “taking special measures for special problems” on land resumption and compensation for Choi Yuen Tsuen earlier, it was believed that it would be difficult for the Government not to adopt similar compensation arrangements in such a large scale development project. If the Government could ensure that affected persons would benefit from the project and their living would not be affected, objections to the project would be largely reduced.
20. Mr LAU Kwok-fan supplemented that:
- (a) the existing road network development planning in North District could only cope with the present traffic flow in the district and might not be able to cope with the transport demand of the new population of 200 000 brought by the NDAs project. Government departments concerned had to improve the traffic network of the district, in particular, conditions at Kai Leng roundabout and Po Shek Wu Road; and
 - (b) the mass transportation capacity of railway in North District had reached its limits. However, it was only stated in the railway development plan of the NDAs project that KTN Station would be provided but there was no mentioning of extension of the railway to areas such as FLN, Queen’s Hill or Ping Che nor increasing the capacity of the East Rail Line. If the NDAs project could not

provide sufficient job opportunities for residents, they would have to go to work in other districts. As encouraged by the government policy, they might choose railway as their major means of transport. In other words, the burden on the capacity of railway in North District would further increase. He considered that the above matters and details of the whole NDAs project should be discussed and handled together with DEVB and the Transport and Housing Bureau (THB). He suggested that representatives of DEVB and THB should be invited to meetings related to the NDAs project in future to answer enquiries on transport issues.

21. Mr LARM Wai-leung supplemented that the congestion problem at Kai Leng roundabout often led to traffic congestion in the district. At the 20th meeting of the Traffic and Transport Committee (T&TC) held on 9 March 2015, Members put forward a proposal suggesting the provision of a flyover at Kai Leng roundabout (T&TC Paper No. 12/2015). He understood that the scale of the works was so large that the proposal might have to be submitted to PlanD or DEVB for consideration. He hoped that DEVB could include the proposal into the NDAs project to carry out improvement works to the traffic flow.

22. Mr WONG Wang-to supplemented that if Fanling Bypass could be extended to KTN connecting the two NDAs so that residents could travel to and from Fanling and Sheung Shui by Fanling Bypass, there would be no need to rely on Kai Leng roundabout or Tai Tau Leng roundabout and that might facilitate traffic movements in North District.

23. In conclusion, Mr CHAN Chun-fung, Michael responded to Members' questions and views as follows:

- (a) DEVB understood views of Members and residents affected by the NDAs project on matters such as compensation, removal and rehousing, and hoped that a proposal responding to appeals of various parties could be devised as soon as possible. At present the Government was still actively considering arrangements of "rehousing in situ" and views of various stakeholders, and would announce to the public once a concrete proposal was available;

and

- (b) taking STL Home and the government quarters at Shek Tsai Leng as examples, if the site formation works of the new RCHEs building could be carried out as soon as possible and the old RCHEs were demolished by two phases, most of the existing RCHEs residents could temporarily stay at RCHEs pending removal by phases and the effect of the works on them could be minimised. An inter-departmental working group was set up to discuss detailed arrangements for removal and demolition of RCHEs with the operator of STL Home. The Government would treat affected business operators, farmers and other residents in the same way and would put forward a proposal for discussion with various stakeholders as soon as possible in the hope that their needs were taken care of.

24. In conclusion, Mr IP Wing Cheung responded to Members' questions and views as follows:

- (a) Regarding the proposed L1 road works near Shek Tsai Leng in KTN NDA, CEDD would holistically examine the works and consider arrangements to reduce areas to be cleared at the first stage works as far as possible and minimise the effects of the works on residents. CEDD would communicate with DEVB and follow up these matters at the inter-departmental working group;
- (b) in response to Mr LAU Kwok-fan's views, existing roads in the vicinity of the proposed L2 road works in FLN NDA would be retained for use until completion of the road works. There would be two public transport interchanges in FLN NDA in future to facilitate residents to go to MTR Fanling or Sheung Shui Stations. Besides, regarding the proposal of extending the railway line to areas such as Queen's Hill, CEDD would maintain communication with THB and would consider whether the proposal was feasible when studying the development of New Territories (NT) North as a whole;
- (c) regarding Kai Leng roundabout, CEDD would relay views put

forward by Members to the government department concerned;

- (d) in response to Mr LIU Kwok-wah's views, in view of the population growth in North District in the past and in future, it was necessary to increase the provision of sewage treatment facilities. In view of public opinions, the Government had tried to identify other feasible locations (e.g. Lo Wu South) for construction of sewage treatment works. However, owing to factors such as ecology of the areas concerned and technology employed, expansion of the existing Shek Wu Hui Sewage Treatment Works was considered to be more appropriate. On the other hand, the Government understood the concern of residents of Sheung Shui Heung about odour emitted from sewage treatment works. In order to minimise the effects of sewage treatment works on residents, the Drainage Services Department had considered covering the facilities as far as possible and providing odour removal facilities when designing the sewage treatment facilities, and environmental design (such as greening) would be included. Moreover, vehicles for transportation of sludge would adopt an enclosed design to reduce odour emission during transportation; and
- (e) since at present it could not be confirmed whether there were other locations suitable for construction of the "police driving and transportation training" and "weapon training" facilities apart from Fu Tei Au, Fu Tei Au was still the planned location for construction of the above facilities according to the present planning.

25. The Chairman concluded that although no objection to the NDAs project was raised among the twelve Members who had given their views and Members also supported the implementation of the road and sewerage works under the advance and first stage works of NDAs as well as the works for the new RCHEs building, he hoped that government departments concerned would listen to Members' views by properly handling STL Home, which was affected by the advance works, and finalizing and announcing the compensation and rehousing proposals as soon as possible in order to put affected stakeholders at ease.

26. Mr LAW Sai-yan supplemented that since problems of L1 road works at Shek Tsai Leng and “seamless transition” were not handled properly, he had reservation about the implementation of the advance works.

27. The Chairman supplemented that views of NDC were given from the perspective of the whole rather than a small part of the development project. Besides, DEVB and CEDD had mentioned that detailed arrangements that had not been finalised would be followed up by the inter-departmental working group, including continued discussion with STL Home. He hoped that CEDD would note the views of Mr LAW Sai-yan.

Item 3: Meeting between Director of Buildings and NDC Members

28. The Chairman, on behalf of NDC, welcomed Mr HUI Siu-wai, JP, Director of Buildings, Mr YIP Wing-chung, Senior Structural Engineer/C5, Existing Buildings Division 1, and Ms NG Ka-yin, Administrative Assistant to the Director of Buildings, to the meeting.

29. Mr HUI Siu-wai made use of PowerPoint to introduce the duties, manpower and work of the Buildings Department (BD). The work of BD included enforcement against unauthorised building works (UBWs), Operation Building Bright (OBB), Mandatory Building Inspection Scheme (MBIS) and Mandatory Window Inspection Scheme (MWIS) and handling water seepage in buildings, etc. The PowerPoint slides were at Annex II.

(Mr LEE Koon-hung, Mr LI Kwok-fung, Mr HAU Chi-keung and Mr LAU Kwok-fan left the meeting at this juncture.)

30. Mr WONG Yun-keung, Simon put forward the following questions and views:

- (a) Continuous water seepage was found in the flat of a household after the flat on the upper floor was renovated into sub-divided units with alteration of drainage works. Although the household

had contacted the Water Supplies Department, the Joint Offices for Investigation of Water Seepage Complaints (hereafter referred to as “the Joint Offices”) and BD, the water seepage problem was still unresolved after more than a year. There were three doors at the entrance of the flat concerned, which was concrete evidence proving that the flat was sub-divided. He asked why BD did not issue a removal order to that sub-divided flat in order to solve the water seepage problem. He also doubted the procedures and capability of BD in handling sub-divided units;

- (b) recently, a housing estate without a property management company or an owners’ corporation in Shek Wu Hui had received a MBIS notice from BD. Due to fragmented ownerships of the housing estate, owners were unable to help the housing estate to participate in the scheme even if they wished to do so. He suggested that BD should co-ordinate with district offices to help these housing estates to form owner’s corporations before issuing MBIS notices to them;
- (c) some residents tried to call BD’s enquiry hotline after receiving removal orders of UBWs but found it difficult to get through to the hotline and often only telephone recording was available after getting through to the hotline. Even when they came into contact with the staff of BD, staff members could not answer their questions clearly. He hoped that BD could send staff members to inspect the flats concerned or issue written replies with photos to give clear instructions to members of the public in respect of their enquiries;
- (d) an old building in Shek Wu Hui demolished its concrete external walls and replaced with window walls. A large television was then placed behind a window wall to broadcast advertisements, which affected nearby residents by creating light pollution and noise nuisances. The above works were approved by BD, and BD asked the affected parties to seek help from the Environmental Protection Department. He did not understand why BD would approve such works and asked BD to carry out a review; and

- (e) some news articles criticised that the large-scale building maintenance programmes introduced by BD had become a large-scale bid-rigging exercise. He asked BD how to prevent large-scale bid-rigging so that owners would not be cheated.

(Mr YIP Yiu-shing, Chris left the meeting at this juncture.)

31. Mr WAN Wo-tat, Warwick gave recognition to the work of BD in respect of OBB and MWIS. He asked BD the progress of implementation of MWIS in North District such as the number of housing estates involved. He also asked BD how to stamp out problems such as outsourcing of work from qualified contractors to unqualified contractors and overcharging, and whether there was a checking system to ensure the service quality of contractors. At last, he asked for the enquiry hotline of BD to facilitate Members to follow up cases.

32. Ms OR Sin-yi, Windy put forward the following views and suggestions:

- (a) When handling water seepage complaints, the Joint Offices would cease the investigation if the source of water seepage could not be identified. She hoped that BD would not cease the investigation but employed more methods such as the more expensive infrared camera to detect the source of water seepage in order to help the public to solve water seepage problems, in particular, the elderly who were incapable of handling water seepage problems; and
- (b) Tin Ping Estate (TPE) was one of the estates under the Tenants Purchase Scheme (TPS). Recently, owners of TPE had received MWIS notices from BD. They would receive statutory notices in not less than two months after receipt of advance notices, and had to carry out inspection and repair works to their windows within two months after the issue of statutory notices. The owners, in particular, the elderly, were at a loss after receiving the advance notices. There were people who claimed themselves as professionals touted for business in the estate and she was concerned that the public would be cheated. She suggested that

BD should cancel the issue of advance notices to owners and issue statutory notices only. The period of statutory notice should extend to six months to allow owners more time to look for contractors so that owners would not have to look for contractors in the district at the same time within two months upon receipt of statutory notices, which resulted in an increase in the works cost and a reduction of quality of works. She suggested that information of registered minor works contractors with specified licence and ways of making enquiries with BD should be attached to the statutory notice.

33. Mr LAW Sai-yan stated that there were many old buildings and single tenement buildings in Luen Wo Hui. Recently, owners of these buildings had received orders in respect of fire services installations from the Fire Services Department (FSD) and BD respectively and it was found that the number of items requested by FSD was more than that of BD. The major difference was that FSD requested the provision of a water tank of 2 000 litre. Owners asked they should follow the order of which department. Besides, according to the assessment of owners, the provision of the water tank might affect structural safety of the building. They had contacted the above two departments but found that they were not well-coordinated. It was hoped that BD could take the lead to explain to FSD that consideration to structural safety of the building had to be given in the provision of the water tank. Moreover, the price for provision of the water tank was quite high. Most of the old buildings in Luen Wo Hui comprised six households on each floor. Since the number of households was small, owners were unable to raise money to appoint a consultant to carry out assessment and write a report in respect of the feasibility of the works. They hoped that BD could assist them by providing drawings or technical advice, and explaining to FSD whether the proposed measures were feasible.

34. Mr PANG Chun-sing, George put forward the following views:

- (a) The Joint Offices had been set up for many years. In the past, they outsourced their work to consultants who carried out inspections in a slipshod manner with low efficiency and effectiveness and often could not identify the source of water

seepage. In all water seepage cases requiring his assistance, the source of water seepage was unable to be identified. He believed that it would be more effective if the outsourced work was carried out by civil servants;

- (b) recently, the village representative of Fanling Wai had received a letter from BD about the clearance of UBWs in New Territories Exempted Houses (hereafter referred to as “village houses”). In 2012, BD and the NT Heung Yee Kuk (HYK) reached a consensus to introduce the Reporting Scheme for UBWs in Village Houses which was concluded at the end of 2012. Afterwards, BD appointed consultants to carry out site inspections at target villages to investigate village houses with UBWs but had not been reported and those with immediate danger. Since many old villagers did not know that if they rebuilt village houses after 8 May 1999, they had to appoint an engineer or a qualified person to supervise the works and to make an application to BD, he hoped that BD could reach a consensus with HYK before carrying out the clearance exercise.

35. Mr LAI Sum stated that he had sought help from the Joint Offices for many times. The Joint Offices would cease the investigation if they could not identify the source of water seepage after carrying out the colour water test. The affected households concerned were very dissatisfied as their problems were not solved and the ability of the Joint Offices was doubted. BD should have new methods and equipment for testing water seepage. He hoped that BD would perform better in handling water seepage problems such as identifying the source of water seepage.

(Mr CHAN Shung-fai left the meeting at this juncture.)

36. Mr WONG Wang-to put forward the following views and suggestions:

- (a) The time between the issue of advance notices and statutory notices of MWIS by BD was often more than a year. Although he understood that the workload of BD was huge, he hoped that BD could shorten the time between the issue of advance notices

and statutory notices. He also suggested that BD should issue the advance notice six months before the issue of the statutory notice so that the public would not be at a loss and have to pay a higher price for finding a contractor urgently; and

- (b) he had obtained information of qualified persons and registered contractors under MWIS from BD's website but found that only the name, telephone, approximate business scope and locations of the companies were provided in the database. Not only no detailed address was provided but some information provided in the database was incorrect, and that was very confusing. He pointed out that since these qualified persons and contractors had to register with BD, it was hoped that BD could update the database regularly.

37. Mr HAU Kam-lam stated that squatter huts were very common in rural areas, which were problems left behind in the course of development of Hong Kong from 1960s to 1980s. At first squatter huts were built with simple materials such as tin sheets, timber or asbestos cement. When they were broken as time passed, occupants carried out repair works with more robust materials such as bricks and metals for the sake of structural safety. However, this practice violated the law about squatter huts so that the squatter registration was cancelled by the Squatter Control Unit of LandsD and occupants even received removal orders from BD. The departments concerned never gave occupants a chance to restore their squatter huts, causing a nuisance to them. He pointed out that the Government, on the one hand, was concerned about structural safety of old buildings, but on the other hand, did not allow squatters to handle the structural safety problem of their squatter huts by themselves. The policies were contradictory to each other. He asked the Director to reflect the problem to the senior staff of the Government and urged the Government to change the policies.

38. Mr TSANG King-chung, Kent put forward the following questions:

- (a) He had handled a case in which a resident complained that the flat on the upper floor was a suspected sub-divided flat. However, BD ceased the investigation when occupants of the suspected

sub-divided flat refused entry of investigators into the flat for investigation. He asked whether these were the procedures of BD in handling these complaints; and

- (b) HD had set up an independent investigation task force to follow up cases of sub-divided units in HOS or TPS flats. He asked whether BD and HD adopted the same standard or method in investigation and enforcement.

39. Mr CHAN Yung appreciated the effectiveness of the staff of BD, in particular the handling of safety problem of old buildings in recent years. He stated that following the development of society, procedures in handling problems became more and more complicated in Hong Kong, and hence causing more problems. He suggested that BD should streamline the procedures under safe conditions and strengthen the training for civil servants and staff members of outsourcing contractors in handling emotional problems and interpersonal relationship. Besides, he quoted the way that the Government handled the recent incident of “excessive lead content in drinking water” as an example and pointed out that when the Government handled a crisis, communication among the Government, the public and the mass media was very important. Actions such as professionals of departments concerned following up the problem in the first instance, officials at the directorate grade convening press conferences, and senior officials going to the community to communicate with the public might reduce misunderstanding, maintain the trust of the public in the Government and control the crisis effectively. As buildings of Hong Kong continued to age, he anticipated that problems faced by BD would also increase correspondingly. He hoped that BD would perform better in handling crisis.

40. Mr HUI Siu-wai responded to Members’ questions, views and suggestions as follows:

- (a) According to the report of a survey conducted by the Census and Statistics Department on sub-divided units earlier, it was estimated that there were 86 400 sub-divided units in private buildings aged over 25 in Hong Kong. Since there was a large number of sub-divided units, BD mainly focused on handling the following

three problems: firstly, whether the sub-divided units would affect fire safety of the building, for example, whether staircases were blocked or doors were installed at unsuitable locations; secondly, whether the sub-divided units would seriously increase the loading of the building and cause structural safety problems; and thirdly, whether the additional drainage installed for the sub-divided units would cause serious water seepage and environmental hygiene problems due to improper handling. BD would decide whether enforcement actions had to be taken subject to the level of seriousness of the above problems. Risk assessment would be carried out for the inspected sub-divided units and removal or discontinuance orders would be issued to sub-divided units whose conditions were the worst;

- (b) regarding suspected sub-divided flats that could not be accessed for investigation, BD would carry out assessment from the lower floor or external environment of the flat concerned. If it was considered necessary to enter the flat for detailed investigation or inspection, BD would apply for a search warrant from the court. If the flat concerned was found not committing the above three serious irregularities after assessment, BD would cease the investigation. Since more than 40 000 reports had to be handled every year, BD had to make better use of resources and could not carry out investigation on an inaccessible suspected sub-divided flat unceasingly and overlooked other cases that required attention;
- (c) in the implementation of MWIS, so far BD had issued nearly 300 000 statutory notices. Since windows without proper maintenance might cause serious accidents, BD hoped that owners would understand their responsibility in maintaining their windows. BD also attached great importance to the quality of services of window inspection service providers. If there were reports against malpractices of window inspection service providers, BD would carry out investigation. If there was evidence showing that the service provider violated the Buildings Ordinance, BD would instigate prosecution. Besides, education was very important. BD would communicate with stakeholders of the industry regularly in order to understand problems they

encountered and advise them on business practices. In the early stage of implementation of MWIS, some members of the public thought that the weather and noise prevention strip alongside windows also had to be changed when windows were replaced. BD had clarified with the industry that the change of weather strip was not an item requested by the code of practice. BD also produced television announcements promulgating that the public had the rights to ask clearly about the content of MWIS. BD would continue the promotion work in this aspect;

- (d) MWIS had been implemented for three years. BD would continue to collect views on MWIS and would consider Members' suggestion of attaching leaflets with useful information or tips to notices. BD would also continue to communicate with owners of different districts, in particular, owners in old areas;
- (e) the purpose of the issue of advance MWIS notices was to let owners make preparation in advance. Since BD had to handle a substantial amount of cases, the issue of statutory notices was delayed. BD would catch up with the progress and issue statutory notices which were due to be issued. MWIS was of a preventive nature, and owners could appoint a qualified person to carry out window inspection at any time and then inform BD of the result. Records would be kept at BD and no window inspection would be requested within a longer period of time. He hoped that Members could help to explain this to owners;
- (f) regarding views about BD not answering calls from enquiry hotline or being slow in returning calls, since the staff of BD often had to carry out field work, they might not be able to answer enquiries in time during office hours. BD had repeatedly reminded staff members to answer recorded telephone messages as soon as possible after field work;
- (g) upon receipt of reports of sub-divided units, basically BD would carry out site inspection. If records of conditions of the building concerned were already available in the database of BD, BD would give a reply according to information in the database. If

there was insufficient information in the database, BD would carry out site inspection;

- (h) there was no problem if a building demolished its concrete external walls and replaced with window walls according to proper procedures as approved. The placement of a large television indoor at the location of the window wall was not governed by the Buildings Ordinance. If the picture or sound broadcasted by the television caused a nuisance to nearby residents, follow-up actions could be considered through other ordinances or by the Deed of Mutual Covenant Manager of the building concerned;
- (i) when the Joint Offices decided to cease the investigation of a case, examination and test had already been carried out for a long time in respect of the case. If the Joint Offices continued to investigate a case that the source of water seepage could not be identified, the case was just dragged and no answer could be found. BD had introduced new ways to investigate water seepage in order to facilitate the identification of the source of water seepage in serious water seepage cases;
- (j) some Members mentioned that there were companies in the market which claimed to have equipment to identify the source of water seepage. The operation principle of the equipment was similar to the infrared camera newly introduced by BD. This was simple equipment which indicated whether there was a difference in humidity at the suspected location of water seepage by measuring the surface temperature of the location in order to prove whether there was water seepage. The test result could only be used as evidence in applications for civil claims. The Joint Offices were enforcing requirements of the law. If it was proved that there was water seepage at the location concerned and a nuisance was caused, the Joint Offices would issue a statutory order and could institute a prosecution to the court against the person who did not comply with the statutory order. The standard for the burden of proof was relatively higher since a criminal prosecution was involved;

- (k) both BD and FSD were enforcement authorities of the Fire Safety (Buildings) Ordinance (Cap 572) (hereafter referred to as “Cap 572”). FSD would suggest improvement measures in respect of fire services installation and equipment for buildings while BD would put forward requirements for improvement of integrity of fire compartmentation and fire escape of buildings. The two departments were closely co-ordinated in these works. After inspection, the two departments basically would issue orders in the capacity of enforcement authorities on the same day requiring owners to carry out improvement works. In the case mentioned by Member, FSD required owners of the building concerned to install a water tank to provide water for the fire sprinkler system or fire hose reels according to the latest standard. Since the structure of the building was often involved, the installation of water tank might not be possible because the structure of the building was not suitable or there was no space for the installation. In the past, owners would discuss with FSD reasons why the water tank could not be installed, and FSD would handle individual cases flexibly on their own merits. If it was suitable for the building to install a water tank, the works would be referred to BD for handling according to normal vetting procedures. BD and FSD would continue to cooperate in the enforcement of Cap 572 and would assist owners in complying with notices of fire safety inspection of buildings;
- (l) regarding the outsourcing arrangements, since the workload of the Joint Offices was very heavy, staff members of the Joint Offices alone were unable to cope with the workload and, therefore, arrangement of outsourcing to consultants had to be maintained. BD had all along followed up comments on improving the service quality of outsourced consultants and arrangements had been made to monitor the performance of consultants;
- (m) regarding the problem of UBWs of village houses, BD had all along closely cooperated with HYK including convening meetings regularly. Rural committees concerned would be informed in advance for every village inspection exercise and actions would

only be taken on condition that villagers understood the situation;

- (n) squatter control policy was not under the purview of BD and he would reflect Members' views to the department concerned. In handling UWBs in NT or in urban areas, BD would act according to the prevailing policy on removal of UWBs. Basically, UWBs not causing serious danger could be set aside temporarily. However, one of the approaches in handling UWBs was prevention of emergence of new UWBs. If a squatter hut was defined as UWBs after the change of materials used, that would fall under the purview of BD; and
- (o) handling of crises was a duty that BD had to face every day. He agreed that it was very important to streamline the procedures and strengthen the emergency response and emotional training of staff members. BD, therefore, now cooperated with social welfare organisations so that social workers would help to explain to the public about arrangements of some special cases.

41. Mr WONG Yun-keung, Simon supplemented that although the conversion of window walls and placement of a large television closely behind the window wall indoor did not endanger building safety, nuisances were caused to residents in the surrounding. Since the works were carried out legally, other departments had no way to solve the problem. He considered that after all, the problem was caused by BD's approval of the works and BD should reflect the problem to the Government. Owners of commercial cum residential buildings in old areas such as Shek Wu Hui might benefit from the above conversion works of window walls as he found that such practice was spreading and considered the Government had to handle the problem. He suggested that BD should consult the locals, nearby residents and households of the building concerned in writing in respect of an application for conversion of external walls before deciding whether to approve the works.

42. Mr PANG Chun-sing, George supplemented that according to the existing policy of BD, if UBWs were found in any works in progress, BD would institute prosecution. LandsD or other departments concerned might refer works in progress involving UBWs to BD. Therefore, the

handling of squatter huts involving UBWs was under the purview of BD.

43. Mr HUI Siu-wai responded that if the squatter registration was cancelled, the case would be handled by BD according to the prevailing policy. Although a squatter hut might have existed for decades, it lost the eligibility after it had been repaired with robust materials and that was the focus of the problem.

44. The Chairman stated that Members had given their views and hoped the Director would accept them if they were feasible. He also hoped that BD would maintain communication with Members if there were any problems. On behalf of NDC, he thanked the Director of Buildings for attending the meeting.

Item 4: Applications for District Council Funds

(NDC Paper No. 42/2015 – Details of Funds Applications)

(NDC Paper No. 43/2015 – Past Records of Organisations in Holding Activities)

45. The Chairman stated that NDC Paper No. 42/2015 set out 44 applications for District Council Funds and an application for change of activity details, totaling 45 applications. The Secretariat prepared NDC Paper No. 43/2015 by consolidating past records of applicant organisations in holding activities for reference of Members in vetting individual applications according to applicant organisations' past performance in holding activities. Besides, the Secretariat prepared a list setting out posts assumed by Members in applicant organisations according to information collected. The list (Annex III) was placed on the conference table for perusal of Members. He asked Members to refer to the list and make amendments or supplements if necessary. No Member made any amendment or supplement to the list.

46. The Chairman stated that a Member if associated with the applicant organisation/co-organiser/assisting organiser of an activity in an executive capacity should keep silent during the vetting of the application and abstain from decision-making or voting for the application concerned. He was the honorary president of both Hong Kong North District Flower,

Bird, Insect And Fish Show Association Limited, which was the applicant organisation of “North District Tourism Promotion Week 2015 (transliteration)”, and North District Juvenile Association, which was the applicant organisation of “North District Best Student Election 2015-2016”. Since he was only associated with the applicant organisations in a normal capacity and he had declared interest, he would hold the discussion, decision-making and voting of the applications concerned if not objected. No Member raised an objection.

47. The Chariman then stated that he was also a Member of North District Arts Advancement Association Limited and the Chairman of Sheung Shui Choi Yuen Estate Merchants Association, which were the co-organisers of “North District Dance Party 2015 in Celebration of the National Day (transliteration)”. The North District Arts Advancement Association Limited was also the co-organiser of “Hong Kong North District (2015) Flower Bird Insect and Fish Show” and the applicant organisation of “Culture and Art in North District 2015 (transliteration)”. Since he was associated with the above organisations in an executive capacity, he would not hold the discussion of these three funding applications to ensure the objectiveness and fairness of NDC.

48. According to the list on the conference table, Mr HAU Kam-lam, the Vice-Chairman of NDC, also assumed some posts in the applicant organisations and co-organisers of the above three activities. In response to the Chairman’s enquiry, Mr HAU stated that he only associated with the organisations in a normal capacity. The Chairman stated that since Mr HAU Kam-lam was only associated with the applicant organisations and co-organisers of the above activities in a normal capacity and he had declared interest, he would hold the discussion, decision-making and voting of the funding applications concerned if not objected. No Member raised an objection.

49. The Chariman then stated that Mr LAU Kwok-fan was the authorised person of the applicant organisation of “North District Best Student Election 2015-2016”, Mr PANG Chun-sing, George was the authorised person of the applicant organisation of “Culture and Art in North District 2015 (transliteration)”, and Mr TANG Kun-nin, Tony was the authorised person of the applicant organisation of “Hong Kong North

District (2015) Flower Bird Insect and Fish Show” and the designated executor of the activity. He asked the above three Members to withdraw from the meeting during the vetting of these funding applications.

50. Since Mr LAU Kwok-fan had left the meeting, the Chairman asked Members to vet the 42 funding applications apart from “North District Dance Party 2015 in Celebration of the National Day (transliteration)”, “Hong Kong North District (2015) Flower Bird Insect and Fish Show” and “Culture and Art in North District 2015 (transliteration)” first.

51. The Council approved 42 funding applications.

52. Mr HAU Kam-lam then hold the discussion of the funding applications of “North District Dance Party 2015 in Celebration of the National Day (transliteration)”, “Hong Kong North District (2015) Flower Bird Insect and Fish Show” and “Culture and Art in North District 2015 (transliteration)”.

(Mr PANG Chun-sing, George and Mr TANG Kun-nin, Tony left the meeting at this juncture.)

53. The Council approved the above three funding applications.

54. Mr HAU Kam-lam stated that since the vetting of the above three funding applications was completed, he would let the Chairman resume the chair of the meeting.

(Mr PANG Chun-sing, George and Mr TANG Kun-nin, Tony returned to the meeting at this juncture.)

55. The 45 funding applications approved were set out at Annex IV.

Reports

Item 5: District Lands Office/North: Returns on Redevelopment of New Territories Exempted House Applications and Small House Applications in North District

(NDC Paper No. 44/2015)

56. The Council noted NDC Paper No. 44/2015.

Item 6: Report of the 3rd Meeting of North District Management Committee in 2015

(NDC Paper No. 45/2015)

57. The Council noted NDC Paper No. 45/2015.

(Mr LAW Sai-yan left the meeting at this juncture.)

Item 7: Reports of Working Groups under NDC

(a) Working Group on Housing and Town Planning of North District

(b) Concern Group on the Construction of Liantang Boundary Control Point

(c) Working Group on Festival Activities

(a) Working Group on Housing and Town Planning of North District

58. Mr LAI Sum reported that the 15th meeting of the Working Group on Housing and Town Planning of North District (HTPWG) was held on 21 July 2015. The representative of HD reported at the meeting the progress of the PH development at Choi Yuen Road Sites 3 and 4 in Sheung Shui (hereafter referred to as “Sites 3 and 4 Project”). The HD representative stated that the foundation works and slope works of Sites 3 and 4 Project were under way while the construction works and drainage connection works were anticipated to commence in 2016. Regarding the suggestion of providing a footbridge connecting the project and the lobby of MTR Sheung Shui Station (hereafter referred to as “the footbridge”),

according to the result of the latest pedestrian survey, HD proposed widening of the pavement under Footbridge No. NF84 (crossing Choi Yuen Road near MTR Sheung Shui Station and Choi Yuk House, Choi Yuen Estate) instead of constructing the footbridge. HTPWG requested that if there was any new housing development in the vicinity of MTR Sheung Shui Station in future, a footbridge connecting the lobby of MTR Sheung Shui Station had to be provided in order to relieve the overcrowding situation of the existing footbridge there. Besides, HTPWG and the HD representative discussed Members' proposal "Request for Changing the Use of Choi Yuen Road Sites 3 and 4 in Sheung Shui for HOS Development to Tie In With the Green Form Subsidised Home Ownership Pilot Scheme". The HD representative stated that there were a number of public facilities provided in Sites 3 and 4 Project, which were difficult to separate from the residential portion. If Sites 3 and 4 Project was to be changed into HOS development, the construction, management and maintenance expenses of these facilities would bring a substantial financial burden to owners. HD, therefore, suggested that Sites 3 and 4 Project should remain as PH development. HTPWG suggested that if HD had any new housing development in the vicinity in future, the project had to be for home ownership development. The representative of District Lands Office/North also reported the latest position of "Vacant Lands Available for Development in North District" at the meeting. As at 30 June 2015, there were 171 pieces of vacant government lands in North District under the management of District Lands Office/North. At last, HTPWG approved an application for funds for community involvement projects named "Change" and "Connect" the Rural and the City (transliteration)' in the amount of \$157,000. The funding application was just approved by the Council.

(b) Concern Group on the Construction of Liantang Boundary Control Point

59. Mr WAN Wo-fai reported that the 4th meeting of the Concern Group on the Construction of Liantang Boundary Control Point was held on 10 November 2014. At the meeting, representatives of CEDD, the Architectural Services Department and LandsD reported the progress of the Liantang/Heung Yuen Wai Boundary Control Point (hereafter referred to as "the Control Point") and associated works, including site formation works

of the Control Point and diversion works of Lin Ma Hang Road as well as construction of Fanling Highway Interchange and associated slip roads. They also answered questions raised by Members in respect of construction of the Control Point and associated facilities. CEDD stated that they would continue to carry out environmental mitigation measures, environmental monitoring work and community relation work in order to minimise the effects of the works of the Control Point on environment and residents.

(c) Working Group on Festival Activities

60. Mr HAU Kam-lam reported that the 11th meeting of the Working Group on Festival Activities (FAWG) was held on 28 July 2015 to discuss the way of implementation of activities of FAWG. This year, there were two activities of FAWG which were under way or scheduled to be carried out, namely “North District Festival Lighting Decoration” and “LOHAS in Autumn, Grassland Music Festival 2015”. Since the dates for holding the above activities partly overlapped with the period of suspension of District Council operation and FAWG could not hold any activities during the suspension period, the North District Office (NDO) was invited to take over “North District Festival Lighting Decoration” solely and to be the organiser of “LOHAS in Autumn, Grassland Music Festival 2015”. FAWG also approved at the meeting an application for funds for community involvement projects submitted by NDO in respect of “LOHAS in Autumn, Grassland Music Festival 2015” in the amount of \$760,000, and an application for change of organiser for “North District Festival Lighting Decoration” by FAWG. These two applications were just approved by the Council.

Item 8: Any Other Business

Suspension of Operation of District Councils

61. Mr YAU Kin-chung stated that the date for holding the fifth District Council ordinary election was 22 November 2015. The nomination period was scheduled to start on 2 October 2015 and run until 15 October 2015. The operation of District Councils would be suspended

from the start of the nomination period until the end of the current term of District Councils, i.e. 31 December 2015. During the suspension of District Council operation, the following activities had to stop:

- (a) Meetings of the District Council and its committees and working groups;
- (b) activities and programmes organised or co-organised by the District Council and its committees and working groups; and
- (c) the Meet the Public Scheme.

Members could refer to the letter issued to them by the Secretariat on 26 June 2015 for details.

Item 9: Date of Next Meeting

62. The Chairman stated that the operation of the current term of District Councils would be suspended from 2 October 2015. This meeting was the last full council meeting of the current term of NDC. He thanked Members and representatives of government departments for their effort made in the past four years for promotion of the well-being of residents of North District.

63. The meeting was adjourned at 1:25 pm.

Secretariat of the North District Council
December 2015

古洞北及粉嶺北新發展區
前期及第一期道路及排污設備工程
與安老院舍大樓地盤平整工程



- 政府於2013年7月公布新界東北新發展區的修訂方案，建議首先推展古洞北及粉嶺北兩個新發展區，作為粉嶺／上水新市鎮的擴展部分，並整合為粉嶺／上水／古洞新市鎮。
- 於2013年12月12日就上述新發展區內前期及第一期工程計劃詳細設計及工地勘測的範圍(區議會文件第75/2013號)諮詢區議會。
- 獲立法會撥款後，土木工程拓展署委託顧問公司為古洞北及粉嶺北新發展區發展計劃前期及第一期工程進行詳細設計。
- 顧問合約已於2014年11月7日展開，而其中初步設計檢討亦已完成。

- 城市規劃委員會於2013年12月20日公布古洞北及粉嶺北的分區計劃大綱草圖，供公眾查閱。經考慮收集到的申述和意見後，城規會於2015年4月29日同意將上述分區計劃大綱草圖遞交行政長官審議。
- 古洞北及粉嶺北的分區計劃大綱草圖亦於2015年6月16日獲得行政長官會同行政會議核准。

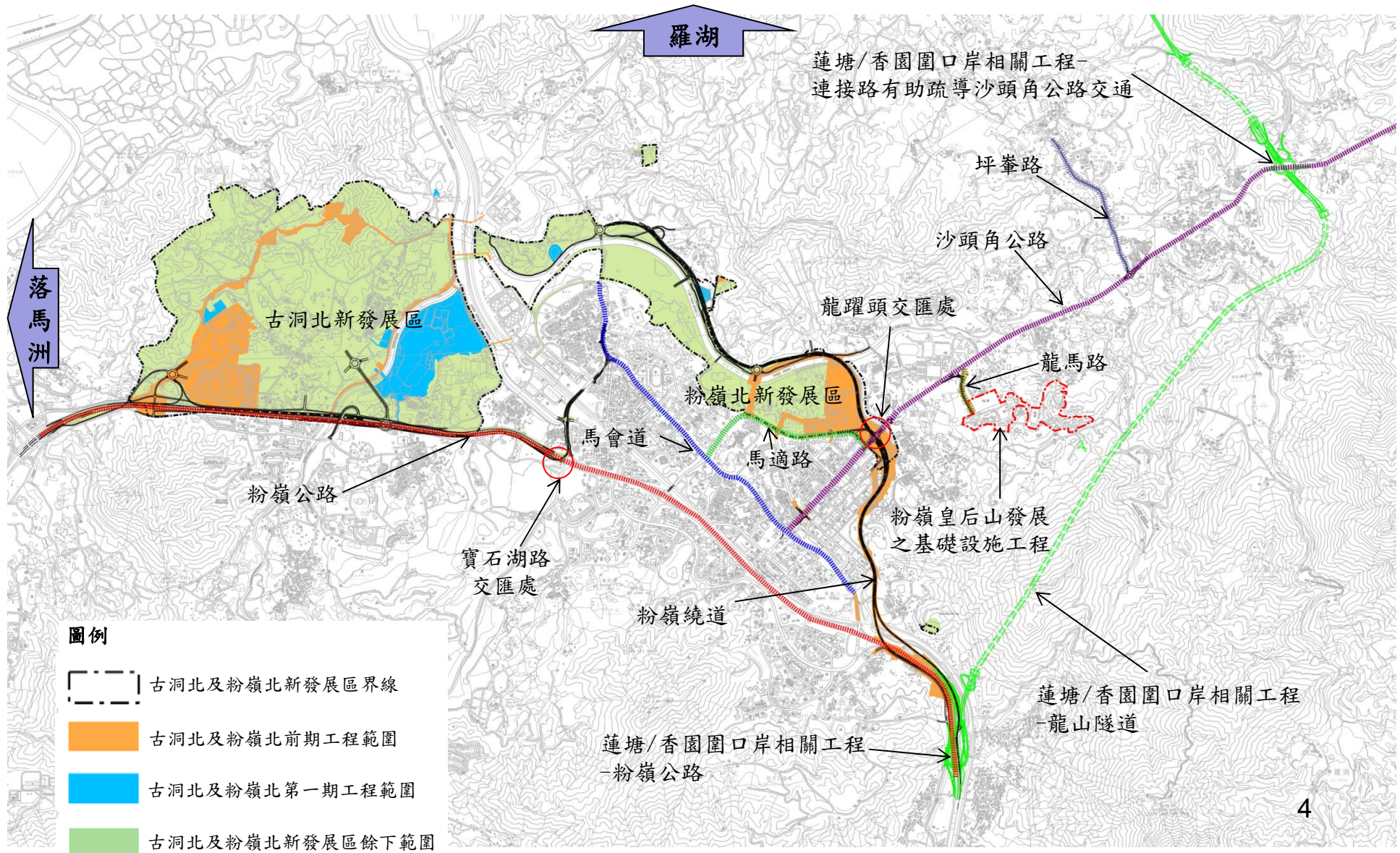





- 前期及第一期的道路及排污設備工程項目
 - 古洞北新發展區：外環路連接粉嶺公路及建造長約4公里的道路；
 - 粉嶺北新發展區：粉嶺繞道東段（由粉嶺公路近塘坑（下）至石湖新村）及建造長約1.6公里的道路；
 - 行人路、單車徑及隔音屏障；及
 - 排污設備

- 安老院舍大樓地盤平整工程
 - 政府擬議在古洞北新發展區內、石仔嶺花園附近的地區興建一座安老院舍大樓以提供不少於1 100個安老宿位的特建合約安老院舍。
 - 地盤平整工程不遲於2016年開展
 - 安老院舍預計於2023年前投入服務

古洞北新發展區 - 道路工程

圖例

-  古洞北新發展區界線
-  前期工程及第一期工程
-  擬建道路/單車徑及相關工程
-  擬建安老院舍大樓及相關工程

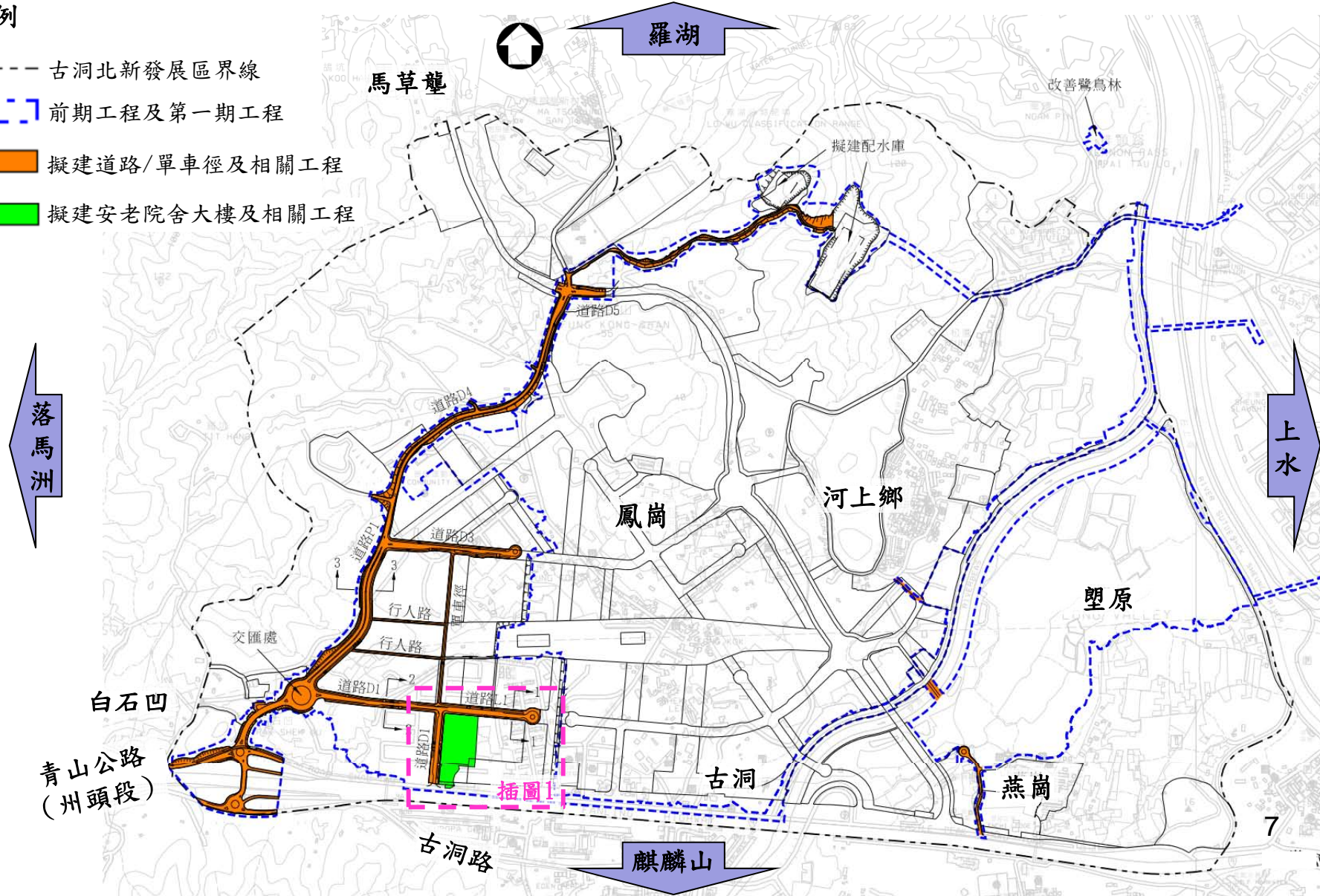

古洞北新發展區 - 排污設備工程

圖例

- 古洞北新發展區界線
- 前期工程及第一期工程
- 擬建排污設備

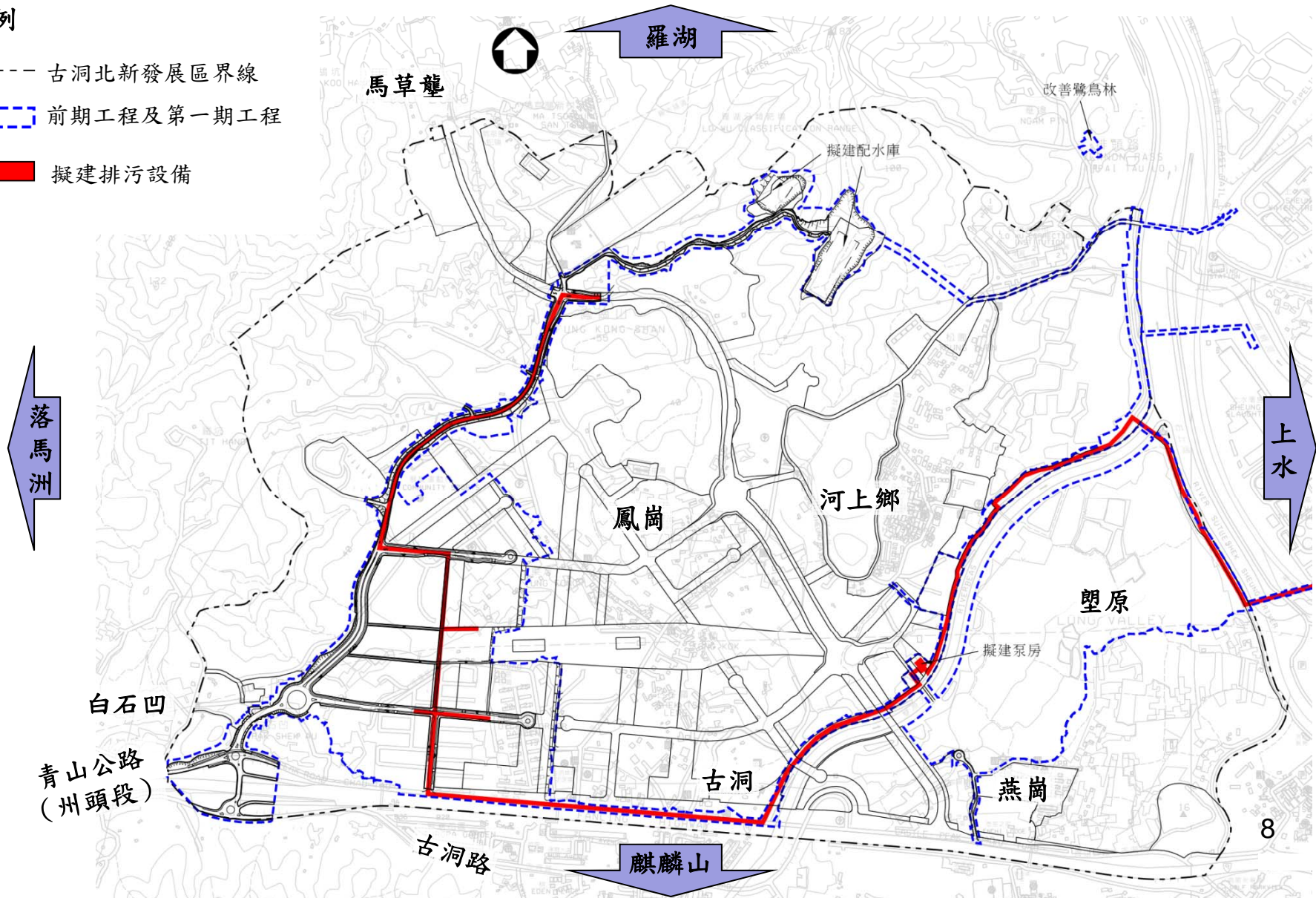

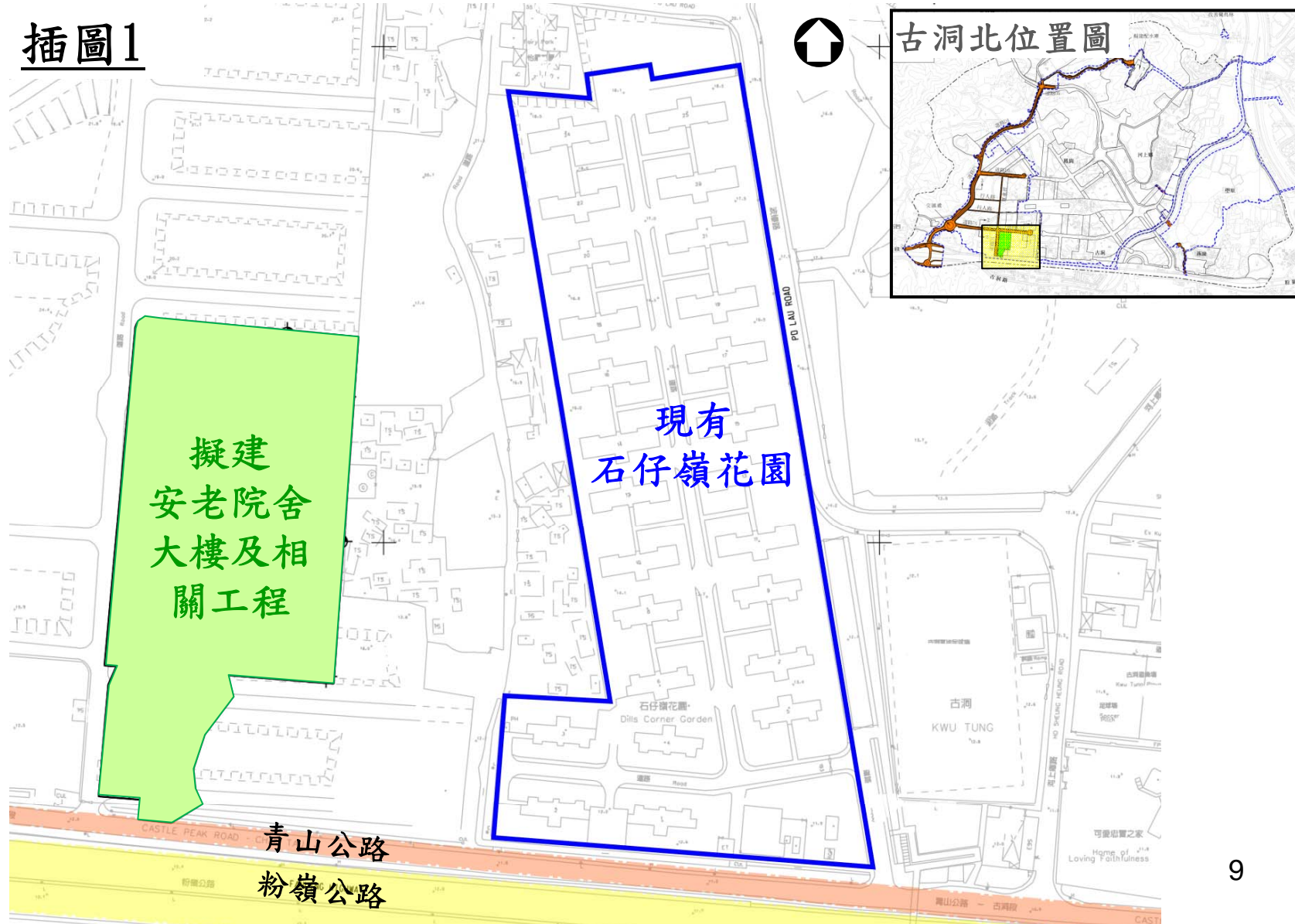

古洞北新發展區-擬建 安老院舍大樓及相關工程

插圖1



粉嶺北新發展區 - 道路工程

圖例

- 粉嶺北新發展區界線
-  前期及第一期工程
-  擬建道路/單車徑及相關工程

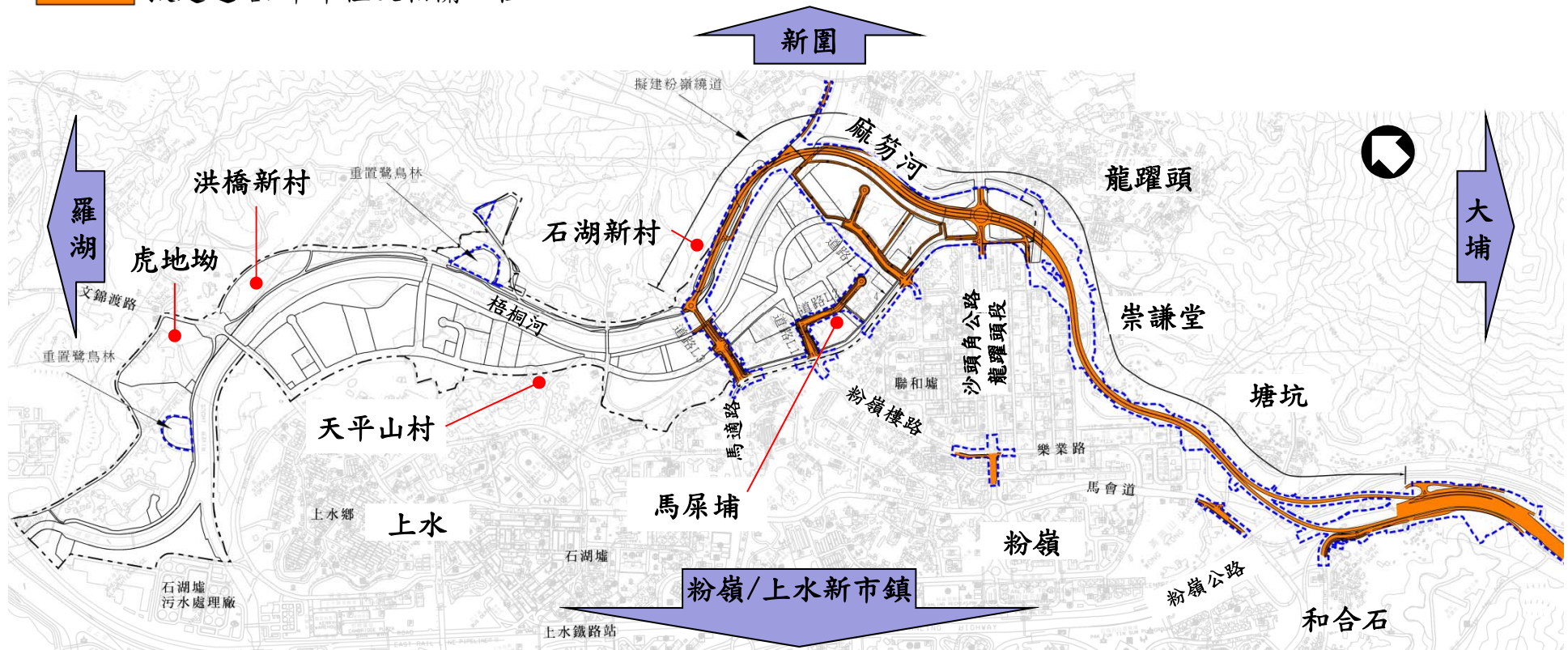

粉嶺北新發展區 - 排污設備工程

圖例

----- 粉嶺北新發展區界線



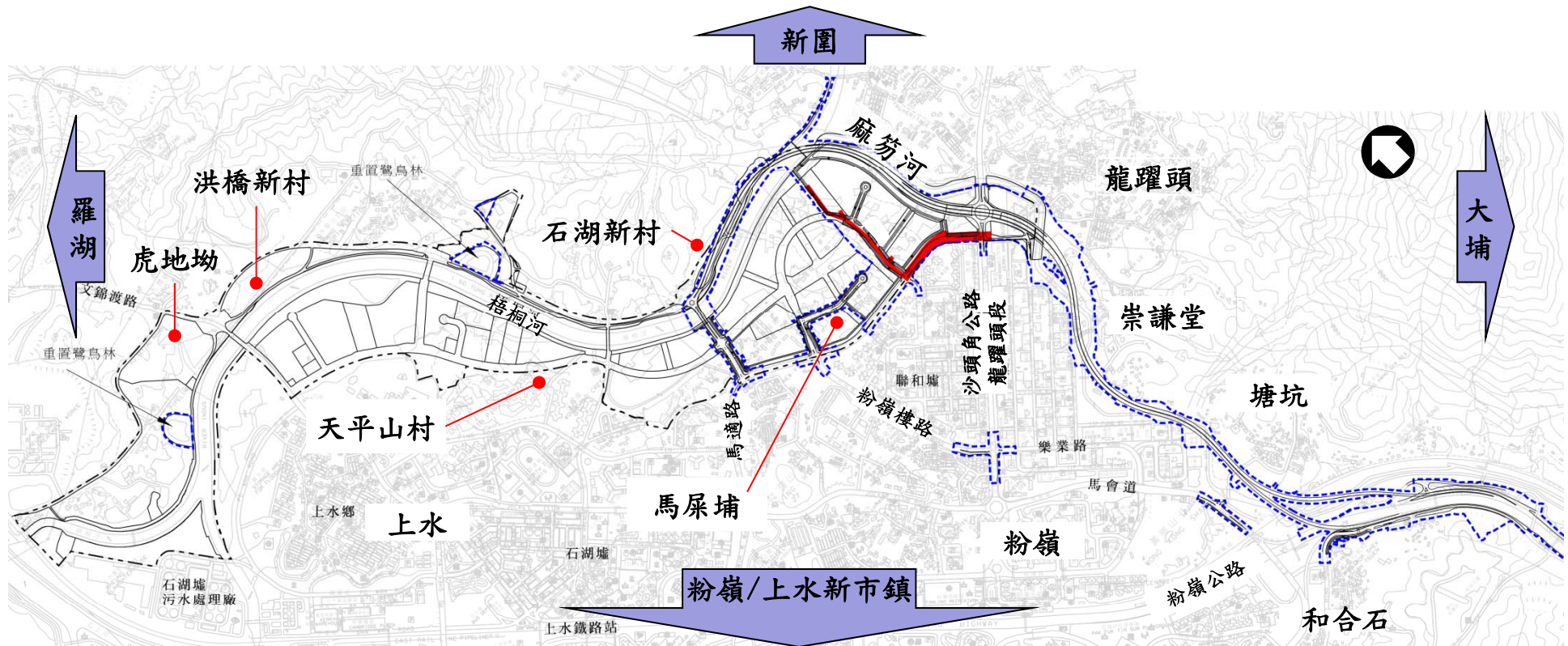

----- 前期及第一期工程

■ 擬建排污設備



粉嶺繞道東段平面圖

圖例

-  前期及第一期工程
-  擬建隧道
-  擬建高架路/橋
-  擬建地面道路

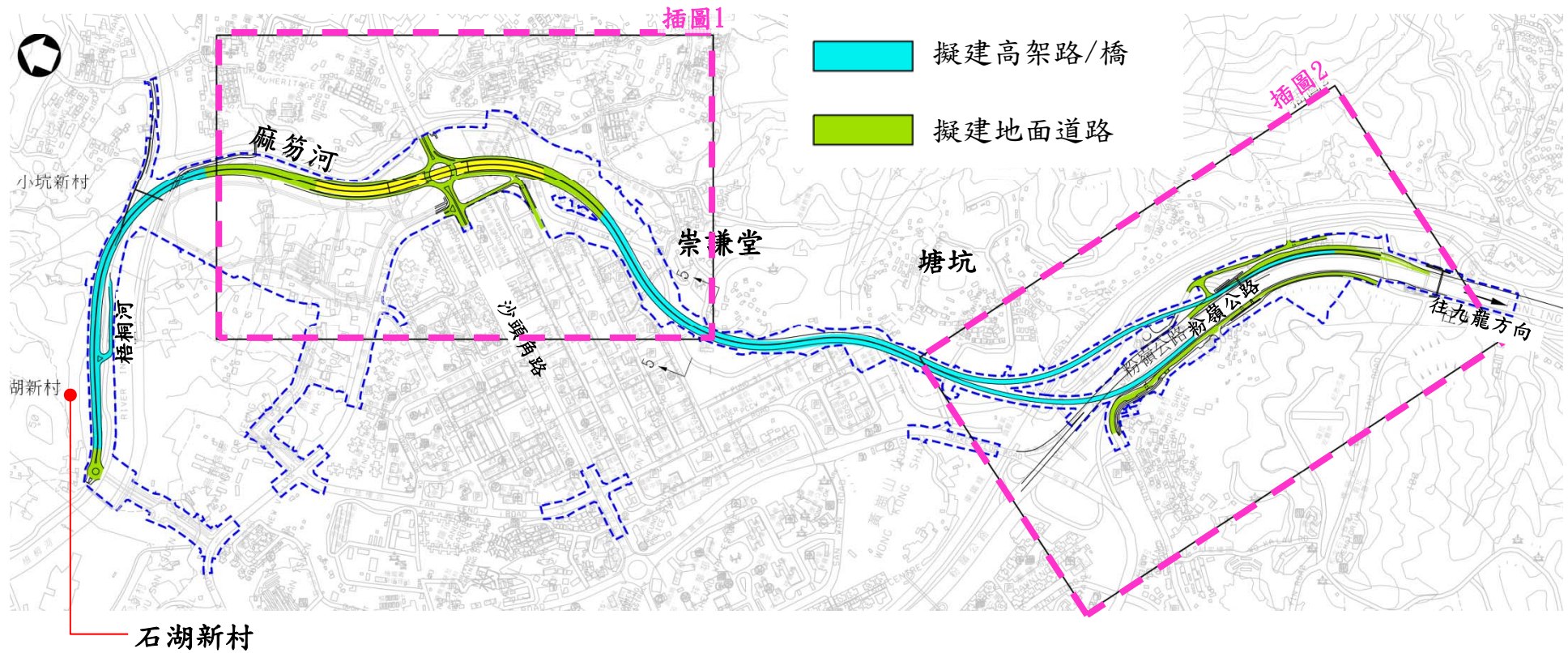

粉嶺繞道東段

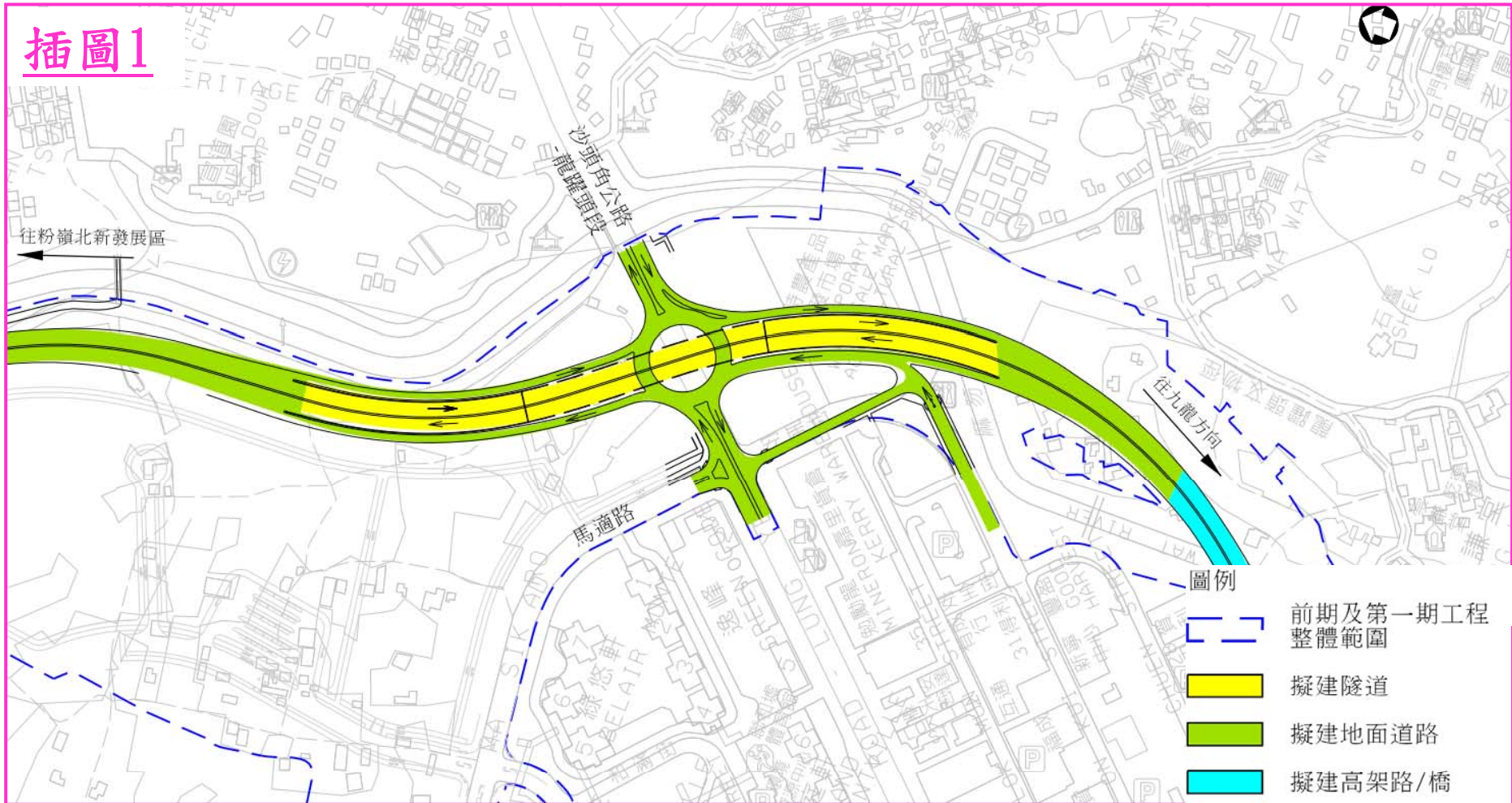

粉嶺繞道東段

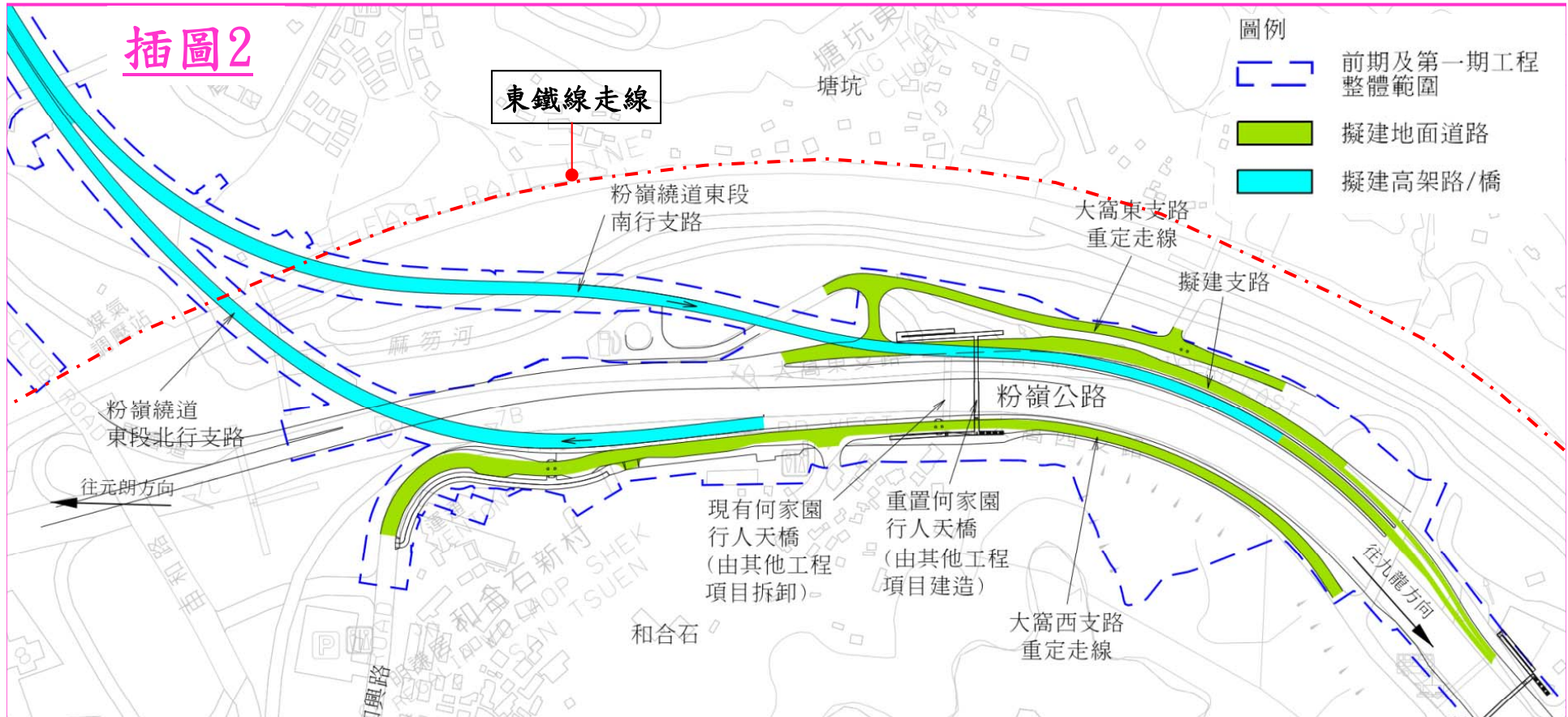

粉嶺繞道東段- 橫切面圖

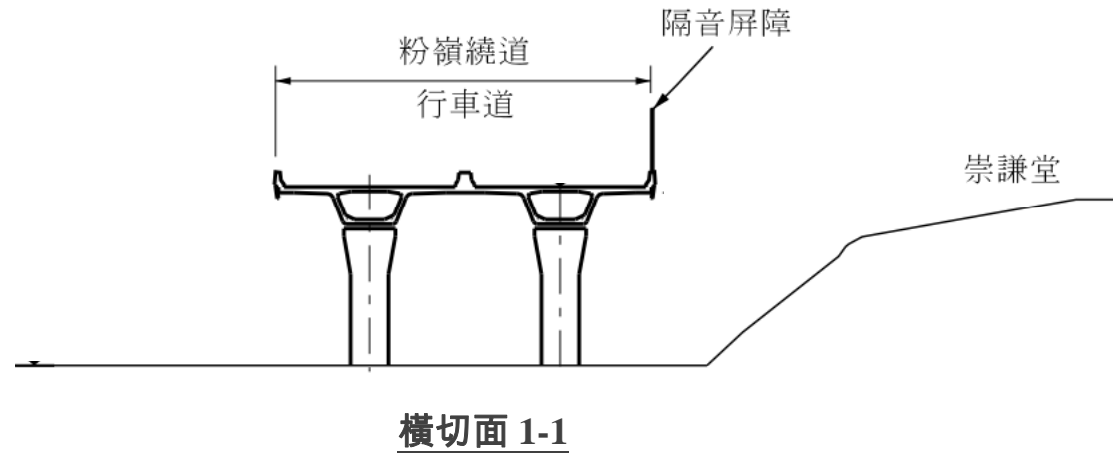
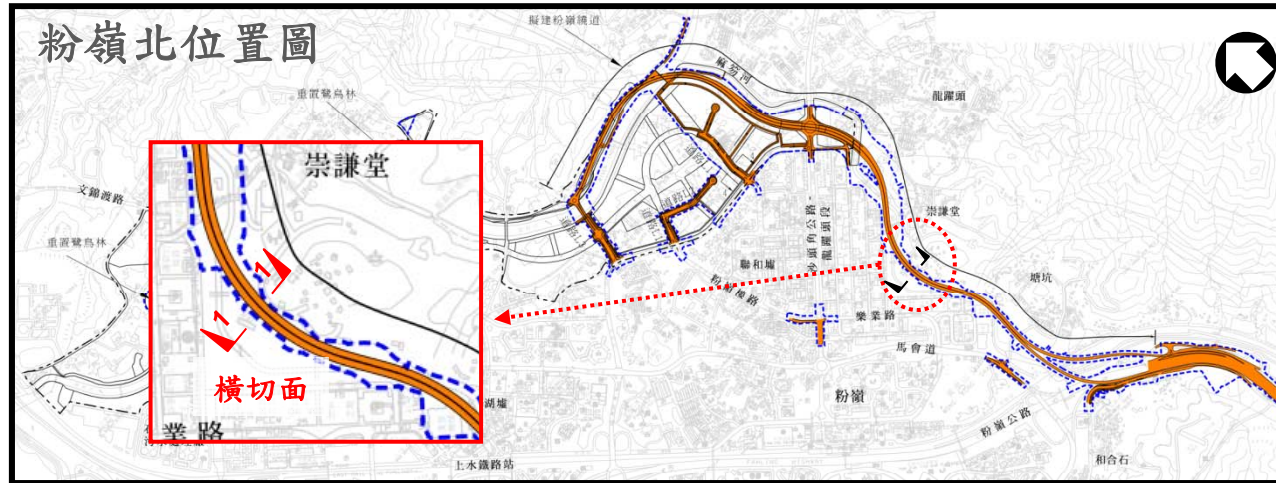

- 根據已批准的環境影響評估報告，有關工程項目在實施建議的緩解措施後，符合相關環保法例及規範的要求
- 工程合約內訂明必須實施合適的緩解措施
- 在新發展區內現有道路進行工程，擬定適當的臨時交通措施維持工程進行期間交通暢順

工程實行計劃



謝謝
歡迎提出對工程的意見

屋宇署署長出席北區區議會

2015年7月30日

屋宇署署長
許少偉

屋宇署的職責

- 根據《建築物條例》的規定，監管私人樓宇及相關建築工程
- 為私人樓宇釐定及施行有關安全、衛生及環境方面的建築標準，旨在改善建築環境的質素
- 推廣樓宇安全

屋宇署的人手 (截至2015年5月)

- 專業人員
 - 屋宇測量師，結構工程師 約**600**名
- 技術人員
 - 測量主任，技術主任 約**570**名
- 一般職系人員 約**550**名
- 總數 約 **1 720**名
- 非公務員合約人員 約**250**名

新建樓宇

- 審批建築圖則
- 就建築工程及地盤安全的事宜進行審查
- 在新樓宇落成後發出“入伙紙”
- 推廣可持續建築設計



新建樓宇的未來挑戰

- 加快審批圖則
- 加強監管建築安全及樓宇質素
- 新發展帶來的工作量 – 西九文化區、東九龍、啟德發展區、市區重建等



現存樓宇

- 約42 000 幢
- 不少有老化、失修情況
- 樓宇安全問題
- 僭建物情況仍然嚴重

2001年開始執行樓宇安全及 適時維修策略以來的部份執法工作

- 拆除超過 400 000 個僭建物
- 清拆 5 400 幢單梯樓宇的天台僭建物
- 清拆超過 23 000 個危險/棄置招牌
- 修葺約 10 000幢失修樓宇

執法工作例子...

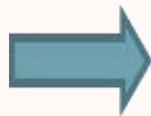
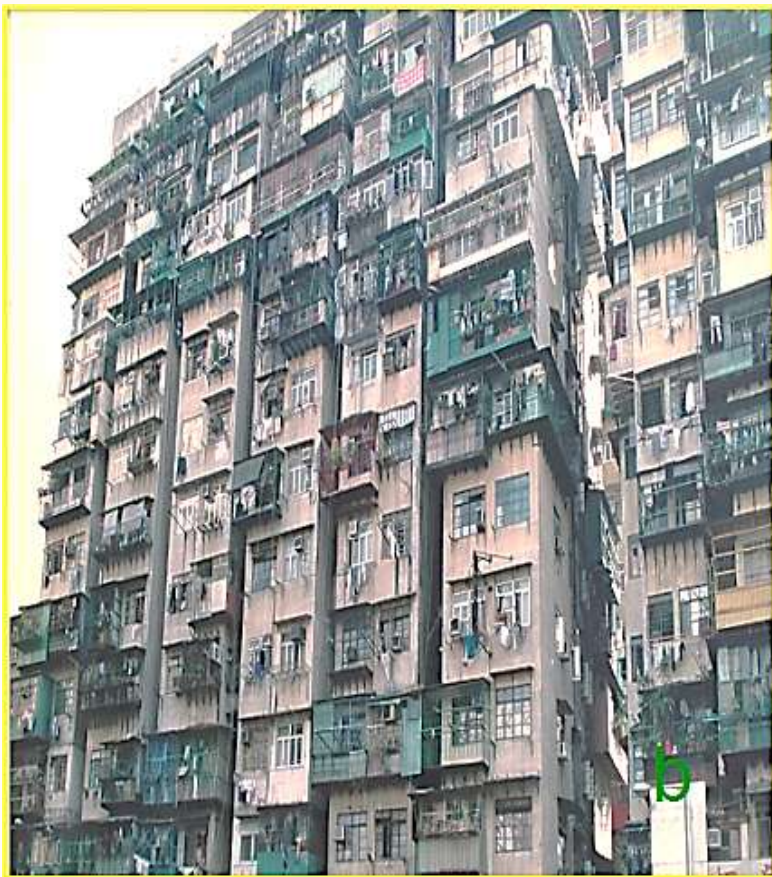

執法工作例子...

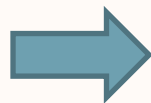

僭建物處理數字

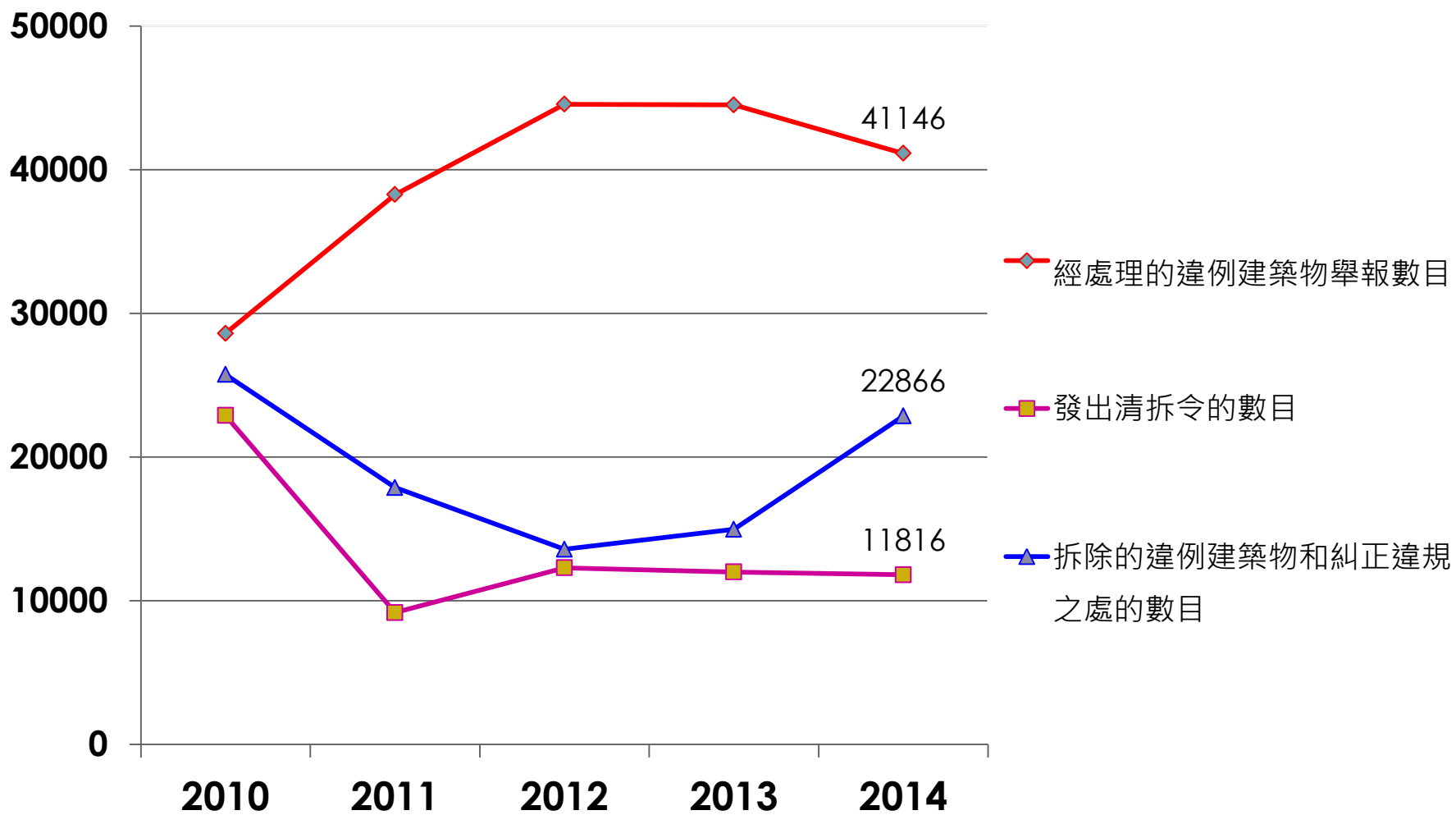

打擊僭建

- 遏止新違建工程
- 減少現有違建工程的數目
- 透過教育和宣傳，提高市民的意識

處理未獲遵從清拆令的 積壓個案

- 成立專責小組清理積壓個案
- 加強檢控未履行法定命令的有關業主

清拆僭建物的執法工作

- 天台、平台、天井及後巷僭建物
- 違規“劏房”
- 新界村屋僭建物
- 新界私人農地僭建物
- 違例/危險/棄置招牌



天台、平台、天井及後巷僭建物的清拆行動

| 天台、平台、天井及後巷僭建物的清拆行動 | | 總計 |
|---------------------|-------------|-------|
| 全港 | 目標樓宇數目 | 2 332 |
| | 已發出清拆令的樓宇數目 | 1 162 |
| 北區 | 目標樓宇樓目 | 50 |
| | 已發出清拆令的樓宇數目 | 24 |

截至2015年5月

處理違規“劊房”大規模行動

| 處理違規“劊房”大規模行動 | | 總計 |
|---------------|-----------|----------------------|
| 全港 | 目標樓宇數目 | 1 093 (包括98幢工業大廈) |
| | 發出法定命令的數目 | 1 721 |
| 北區 | 目標樓宇數目 | 14 |
| | 發出法定命令的數目 | 5 |

截至2015年5月

新界村屋僭建物的執法工作

1) 處理新界村屋僭建物的大規模行動(2012年4月展開)

| | 全港 | 北區 |
|------------|--------|-----------------|
| 已完成巡查的鄉村數目 | 84 | 8 ^{註1} |
| 已完成勘察的村屋數目 | 18 015 | 1 970 |
| 發出清拆令的數目 | 520 | 38 |

截至2015年5月

註1：位於北區已巡查的村落有坑頭、塘坑、麻雀嶺、營盤、雞嶺、嶺仔、龍躍頭及坪洋

2) 村屋僭建物申報計劃 (1.4.12- 31.12.12)

| | 全港 | 北區 |
|-----------|--------|------------|
| 已接獲申報表格數目 | 18 034 | 1 263 (7%) |

新界私人農地僭建物的執法工作

屋宇署的執法範圍

- 1) 已完工的僭建物
 - 對生命財產明顯構成威脅
 - 有迫切危險

- 2) 正在施工和新建的僭建物
 - 構築物超越《建築物條例(新界適用)條例》附表豁免證明書的大小



違例/危險/棄置招牌的執法工作

1) 清拆大型違例招牌的大規模行動

2) 清拆危險/棄置招牌

3) 違例招牌檢核計劃:-

- 自願性質
- 適用於一些規模較小及潛在風險較低的現存違例招牌
- 需為招牌進行檢查、鞏固及核證其結構安全，有關招牌便可以繼續保留使用，往後每隔五年須再重新進行安全檢核



推廣樓宇安全

- 樓宇更新大行動 (OBB)
- 小型工程監管制度
- 強制驗樓及驗窗計劃

樓宇更新大行動

- 2009年5月開始推行
- 屋宇署、香港房屋協會及市區重建局
- 協助樓齡超過30年的私人樓宇進行維修
- 斥資35億元
- 受惠於「樓宇更新大行動」的樓宇數目

| | 第一類別 | 第二類別 | 總計 |
|----|-------|-------|-------|
| 全港 | 1 585 | 1 485 | 3 070 |
| 北區 | 2 | 13 | 15 |

截至2015年5月



小型工程監管制度

- 2010年12月31日實施
- 無須事先獲屋宇署批准圖則
- 為業主提供合法、簡易、安全及方便的途徑，進行小型工程，合共126項「小型工程」
- 檢核計劃
- 截至2015年5月，已接獲超過340,000宗小型工程申請



強制驗樓及強制驗窗計劃

- 2012年6月30日全面實施
- **預防勝於治療** 的理念
從根源解決樓宇失修問題



| | 強制驗樓計劃 | 強制驗窗計劃 |
|--------|-----------------------|---------|
| 目標樓宇樓齡 | 30 年或以上 | 10 年或以上 |
| 檢驗項目 | 公用部分和外牆 (包括伸出物、招牌) | 所有窗戶 |
| 服務提供者 | 註冊檢驗人員 | 合資格人士 |



強制驗樓及強制驗窗計劃

| | | 同時進行 驗樓及驗窗 | 只進行驗窗 |
|----|------------|-------------------------------|---------------|
| 全港 | 已選定的目標樓宇數目 | 3 543 | 4 241 |
| | 已發出的通知數目 | 39 559(驗樓通知) 106 745(驗窗通知) | 150 824(驗窗通知) |
| 北區 | 已選定的目標樓宇數目 | 80 | 96 |
| | 已發出的通知數目 | 71(驗樓通知) 694(驗窗通知) | 3 381(驗窗通知) |

截至2015年5月

強制驗樓及強制驗窗計劃

對業主的支援

- 定期在各區舉辦簡介會
- 強制驗樓資助計劃
- 樓宇維修綜合支援計劃
- 技術諮詢服務 (房協及市建局)



樓宇滲水



- 屬樓宇管理和保養問題
- 當滲水問題造成公眾衛生滋擾、影响樓宇結構安全或浪費食水，政府可行使有關法例賦予的權力介入處理個案
- 聯合辦事處於2006年成立，由食物環境衛生署及屋宇署組成
- 屋宇署人員的角色是協助找出滲水源頭
- 確証滲水源頭後，根據《公眾衛生及市政條例》向有關人士發出「妨擾事故通知」

樓宇滲水

- 非破壞性測試
- 傳統測試
 - 濕度水平量度、色水測試、蓄水測試、反向壓力測試
 - 直接有效，能確切找出滲水源頭
- 較新探測儀器
 - 紅外線探測儀和微波探測儀
 - 2013年開始以試用形式使用
 - 協助了解濕度的情況
 - 無法直接找出滲水源頭
 - 費用較高



微波探測儀

紅外線探測儀

- 掃描測量表面溫差
- 間接地評估表面濕度

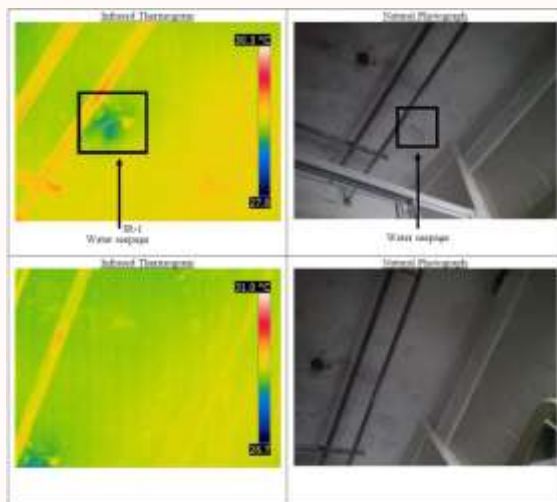

紅外線造影

微波探測儀

- 利用微波頻譜中特定頻率
- 探測滲漏水分佈情況

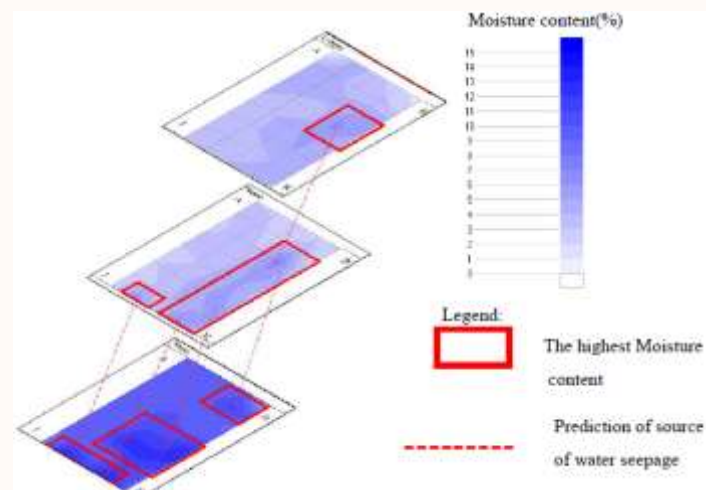

微波濕度立體造型

- 協助了解濕度的情況
- 提升機會找出滲水源頭

樓宇滲水

| | 2013 | | 2014 | |
|--------------------------------|--------|--------|--------|--------|
| 接獲的舉報數目 | 28 504 | | 27 896 | |
| 已處理的舉報數目 | 24 856 | (100%) | 22 056 | (100%) |
| ● 甄別為不予調查的個案 ^{註1} | 13 062 | (53%) | 10 961 | (50%) |
| ● 完成調查的個案 | 11 794 | (47%) | 11 095 | (50%) |
| - 調查期間滲水情況停止 | 4 766 | (19%) | 4 146 | (19%) |
| - 找出滲水源頭 | 4 692 | (19%) | 4 816 | (22%) |
| - 未能找出滲水源頭並終止調查 | 2 336 | (9%) | 2 133 | (9%) |
| 根據《公眾衛生及市政條例》 發出「妨擾事故通知」的數目 | 4 015 | | 4 700 | |

註1：有些個案不在聯辦處可根據法定權限採取跟進行動的範圍內，包括缺乏理據的個案和舉報人撤回的個案，因此不會予以調查。

提升成效和效率

- 聯合辦事處已實行多項措施，包括
 - 擬定調查工作的內部指引
 - 制訂指標以監察調查工作的進度
- 將委託顧問進行研究，檢視可查證樓宇滲水源頭的最新科技方法
- 聯辦處的運作恆常化

屋宇署未來的挑戰

- 優化現行法例及設計標準
- 繼續改善現有建築物的安全及衛生狀況
- 積極推動強制驗樓和驗窗的工作
- 善用資源、簡化工作流程

總結

- 市民舉報僭建物數字持續上升，反映他們日益重視樓宇安全問題
- 加強教育及宣傳，向樓宇業主灌輸適時維修樓宇的文化
- 與伙伴機構研究加強對有需要樓宇業主的支援及協助
- 對不願意清拆僭建物的業主或不願意安排樓宇維修的業主採取適當的執法行動，確保樓宇及公眾安全

謝謝



屋宇署
BUILDINGS
DEPARTMENT

努力不懈 突破目標

We Go the Extra Mile

The 23rd Meeting of North District Council (2012-2015)
Applications for District Council Funds and Application for Change of
Activity Details of Community Involvement Projects
**Posts Assumed by District Council Members in Applicant Organisations/
 Co-organisers/Assisting Organisers of Activities**

| Name of Activity | North District National Day Reception in Celebration of the 66th Anniversary of the Founding of the People's Republic of China (transliteration) | North District Carnival in Celebration of the 66th National Day (transliteration) | North District Evening Party in Celebration of the 66th National Day (transliteration) |
|----------------------------------|--|--|--|
| Applicant Organisation(s) | North District Council Publicity Working Group | North District Communities National Day Celebration Organizing Committee | North District Communities National Day Celebration Organizing Committee |
| Co-organiser(s) | - | - | - |
| Assisting Organiser(s) | - | - | - |
| Mr SO Sai-chi, SBS, MH | | | |
| Mr HAU Kam-lam, MH, JP | | | |
| Mr WONG Yun-keung, Simon | | | |
| Mr LEE Koon-hung | | | |
| Mr LI Kwok-fung | | | |
| Ms LAM Lai-fong, Fanny | | Vice-Secretary-General of North District Communities National Day Celebration Organizing Committee | Vice-Secretary-General of North District Communities National Day Celebration Organizing Committee |
| Mr HAU Chi-keung | | | |
| Mr YIU Ming | | | |
| Ms OR Sin-yi, Windy | | | |
| Mr CHAN Yung, BBS, JP | | | |
| Mr CHAN Shung-fai | | | |
| Mr PANG Chun-sing, George, MH | | | |
| Mr TSANG King-chung, Kent | | | |
| Mr WONG Wang-to | | | |
| Mr WAN Wo-tat, Warwick | | | |
| Mr WAN Wo-fai, MH | | | |

| | | | |
|--------------------------------|--|--|--|
| Mr YIP Yiu-shing, Chris, MH | | | |
| Mr LLU Kwok-wah | | | |
| Mr LAU Kwok-fan, MH | | | |
| Mr TANG Kun-nin, Tony, MH | | | |
| Mr LAI Sum | | | |
| Mr LARM Wai-leung | | | |
| Mr LAW Sai-yan | | | |
| Mr TAM Kin-keung, Terry, MH | | | |

| | |
|----------------------------------|---|
| Name of Activity | North District Dance Party 2015 in Celebration of the National Day (transliteration) |
| Applicant Organisation(s) | North District Residents Association Limited |
| Co-organiser(s) | North District Communities National Day Celebration Organizing Committee |
| Assisting Organiser(s) | North District Dance Association, North District Women's Association, North District Juvenile Association, North District Arts Advancement Association Limited, Sheung Shui Choi Yuen Estate Merchants Association, Hong Kong Sport Education Association (North District Branch) |
| Mr SO Sai-chi, SBS, MH | Honorary President of North District Residents Association Limited Honorary President of North District Juvenile Association Member of North District Arts Advancement Association Limited Chairman of Sheung Shui Choi Yuen Estate Merchants Association |
| Mr HAU Kam-lam, MH, JP | Honorary President of North District Residents Association Limited Honorary Vice-President of North District Juvenile Association President of North District Arts Advancement Association Limited |
| Mr WONG Yun-keung, Simon | Executive Member of North District Residents Association Limited Honorary Vice-President of North District Juvenile Association |
| Mr LEE Koon-hung | |
| Mr LI Kwok-fung | Permanent Honorary President of North District Residents Association Limited |
| Ms LAM Lai-fong, Fanny | Vice-Chairman of North District Residents Association Limited Vice-Secretary-General of North District Communities National Day Celebration Organizing Committee President of North District Juvenile Association |
| Mr HAU Chi-keung | |
| Mr YIU Ming | Honorary Vice-President of North District Residents Association Limited Vice-Chairman of North District Juvenile Association |
| Ms OR Sin-yi, Windy | Secretary of North District Residents Association Limited Honorary Vice-President of North District Juvenile Association |
| Mr CHAN Yung, BBS, JP | Honorary President of North District Residents Association Limited Honorary Vice-President of North District Juvenile Association |
| Mr CHAN Shung-fai | |
| Mr PANG Chun-sing, George, MH | Executive Member of North District Residents Association Limited Honorary Vice-President of North District Juvenile Association Chairman of North District Arts Advancement Association Limited |
| Mr TSANG King-chung, Kent | Honorary Vice-President of North District Residents Association Limited Honorary Vice-President of North District Juvenile Association |
| Mr WONG Wang-to | Honorary Vice-President of North District Residents Association Limited Honorary Vice-President of North District Juvenile Association |
| Mr WAN Wo-tat, Warwick | Honorary Vice-President of North District Juvenile Association |
| Mr WAN Wo-fai, MH | Executive Member of North District Residents Association Limited Honorary Vice-President of North District Juvenile Association |
| Mr YIP Yiu-shing, Chris, MH | Permanent Honorary Consultant of North District Residents Association Limited Honorary Vice-President of North District Juvenile Association |
| Mr LLU Kwok-wah | |

| | |
|-----------------------------|---|
| Mr LAU Kwok-fan, MH | Honorary Vice-President of North District Residents Association Limited Chairman of North District Juvenile Association |
| Mr TANG Kun-nin, Tony, MH | Permanent Honorary Consultant and Vice-Chairman of North District Residents Association Limited Honorary Vice-President of North District Juvenile Association |
| Mr LAI Sum | Honorary Vice-President of North District Residents Association Limited Honorary Vice-President of North District Juvenile Association |
| Mr LARM Wai-leung | Vice-Chairman of North District Residents Association Limited Honorary Vice-President of North District Juvenile Association |
| Mr LAW Sai-yan | |
| Mr TAM Kin-keung, Terry, MH | |

| | | | | |
|----------------------------------|---|---|---|---|
| Name of Activity | Hong Kong North District (2015) Flower Bird Insect and Fish Show | North District Youth Festival - Showing Talent with Creativity and Energy (transliteration) | North District Fire Safety Day | Production of Fire Safety Promotion Materials |
| Applicant Organisation(s) | Hong Kong North District Flower, Bird, Insect And Fish Show Association Limited | North District Youth Programme Committee | Working Group on Fire Safety Activities of North District Fire Safety Committee | Working Group on Fire Safety Activities of North District Fire Safety Committee |
| Co-organiser(s) | - | - | - | - |
| Assisting Organiser(s) | CLP Power Hong Kong Limited, North District Arts Advancement Association Limited, African Violet Association of Hong Kong, Chinese Cymbidium General Association of Hong Kong Limited, Hong Kong Artistic Orchid Association, Hong Kong Oriental Orchid Association Limited, Hongkong and Kowloon Flower and Plant Workers General Union, Po Sang Yuen Bee Farm, Hong Kong Federation of Overseas Chinese Associations, New Territories School Head Association, North District Secondary School Principals' Association, North District Primary School Heads Association | - | - | - |
| Mr SO Sai-chi, SBS, MH | Honorary President of Hong Kong North District Flower, Bird, Insect And Fish Show Association Limited Member of North District Arts Advancement Association Limited | | | |
| Mr HAU Kam-lam, MH, JP | Vice-President of Hong Kong North District Flower, Bird, Insect And Fish Show Association Limited President of North District Arts Advancement Association Limited | | | |
| Mr WONG Yun-keung, Simon | Honorary Consultant of Hong Kong North District Flower, Bird, Insect And Fish Show Association Limited | | | |
| Mr LEE Koon-hung | | | | |
| Mr LI Kwok-fung | | | | |
| Ms LAM Lai-fong, Fanny | | | | |
| Mr HAU Chi-keung | | | | |
| Mr YIU Ming | Honorary Consultant of Hong Kong North District Flower, Bird, Insect And Fish Show Association Limited | | | |

| | | | | |
|----------------------------------|---|--|--|--|
| Ms OR Sin-yi, Windy | | | | |
| Mr CHAN Yung, BBS, JP | | | | |
| Mr CHAN Shung-fai | | | | |
| Mr PANG Chun-sing, George, MH | Member of Hong Kong North District Flower, Bird, Insect And Fish Show Association Limited Chairman of North District Arts Advancement Association Limited | | | |
| Mr TSANG King-chung, Kent | | | | |
| Mr WONG Wang-to | Honorary Consultant of Hong Kong North District Flower, Bird, Insect And Fish Show Association Limited | | | |
| Mr WAN Wo-tat, Warwick | | | | |
| Mr WAN Wo-fai, MH | Honorary Consultant of Hong Kong North District Flower, Bird, Insect And Fish Show Association Limited | | | |
| Mr YIP Yiu-shing, Chris, MH | | | | |
| Mr LLU Kwok-wah | Honorary Consultant of Hong Kong North District Flower, Bird, Insect And Fish Show Association Limited | | | |
| Mr LAU Kwok-fan, MH | Honorary Consultant of Hong Kong North District Flower, Bird, Insect And Fish Show Association Limited | | | |
| Mr TANG Kun-nin, Tony, MH | Chairman and Authorised Person of Hong Kong North District Flower, Bird, Insect And Fish Show Association Limited and Designated Executor of the Activity | | | |
| Mr LAI Sum | Honorary Consultant of Hong Kong North District Flower, Bird, Insect And Fish Show Association Limited | | | |
| Mr LARM Wai-leung | Honorary Consultant of Hong Kong North District Flower, Bird, Insect And Fish Show Association Limited | | | |
| Mr LAW Sai-yan | | | | |
| Mr TAM Kin-keung, Terry, MH | Honorary Consultant of Hong Kong North District Flower, Bird, Insect And Fish Show Association Limited | | | |

| Name of Activity | Open Day for Fanling Fire Station cum Fanling Ambulance Depot | Fire Safety Competition | Promotion Activities of Prevention of Hill Fires | Young People@NICE! (transliteration) |
|-------------------------------|---|---|---|--|
| Organiser(s) | Working Group on Fire Safety Activities of North District Fire Safety Committee | Working Group on Fire Safety Activities of North District Fire Safety Committee | Working Group on Fire Safety Activities of North District Fire Safety Committee | North District Civic Education Committee |
| Co-organiser(s) | - | - | - | - |
| Assisting Organiser(s) | - | - | - | - |
| Mr SO Sai-chi, SBS, MH | | | | |
| Mr HAU Kam-lam, MH, JP | | | | |
| Mr WONG Yun-keung, Simon | | | | |
| Mr LEE Koon-hung | | | | |
| Mr LI Kwok-fung | | | | |
| Ms LAM Lai-fong, Fanny | | | | |
| Mr HAU Chi-keung | | | | |
| Mr YIU Ming | | | | |
| Ms OR Sin-yi, Windy | | | | |
| Mr CHAN Yung, BBS, JP | | | | |
| Mr CHAN Shung-fai | | | | |
| Mr PANG Chun-sing, George, MH | | | | |
| Mr TSANG King-chung, Kent | | | | |
| Mr WONG Wang-to | | | | |
| Mr WAN Wo-tat, Warwick | | | | |
| Mr WAN Wo-fai, MH | | | | |
| Mr YIP Yiu-shing, Chris, MH | | | | |
| Mr LLU Kwok-wah | | | | |
| Mr LAU Kwok-fan, MH | | | | |
| Mr TANG Kun-nin, Tony, MH | | | | |
| Mr LAI Sum | | | | |
| Mr LARM Wai-leung | | | | |
| Mr LAW Sai-yan | | | | |
| Mr TAM Kin-keung, Terry, MH | | | | |

| | | | | |
|----------------------------------|---|--|--|--|
| Name of Activity | North District Community Participation Scheme for Youth 2015 (transliteration) | North District Anti-drug and Fight Crime Variety Show 2015 (transliteration) | Senior Police Call Scheme | Tai Po District School Fight Crime Scheme 2015 – Generation Y Scheme (transliteration) |
| Applicant Organisation(s) | North District Civic Education Committee | North District Fight Crime Committee | Hong Kong Police Force Border District | Hong Kong Police Force Tai Po District |
| Co-organiser(s) | HHCKLA Buddhist Ching Kok Lin Association School, De La Salle Secondary School, N.T., Fanling Rhenish Church Secondary School, Wai Chow Public School (Sheung Shui), Caritas Fanling Chan Chun Ha Secondary School, Yuk Yin School, Hong Kong Taoist Association Tang Hin Memorial Secondary School, Alliance Primary School, Sheung Shui, Elegantia College (Sponsored By Education Convergence), HHCKLA Buddhist Ma Kam Chan Memorial English Secondary School, Shek Wu Hui Public School, Fung Kai Innovative School, TWGHs Li Ka Shing College, HHCKLA Buddhist Chan Shi Wan Primary School, The Boys & Girls Clubs Association of Hong Kong Jockey Club Fanling Children & Youth Integrated Services Centre, Heep Hong Society Fanling Parents Resource Centre, Hong Kong Evangelical Church Bradbury Sheung Shui Family Centre, Hong Kong Evangelical Church School Services Team, Hong Kong Evangelical Church Yan Lam Community Service Centre, Hong Kong Children & Youth Services Jockey Club Fanling Integrated Children & Youth Services Centre | - | - | - |
| Assisting Organiser(s) | - | - | - | - |
| Mr SO Sai-chi, SBS, MH | | | | |
| Mr HAU Kam-lam, MH, JP | | | | |
| Mr WONG Yun-keung, Simon | | | | |
| Mr LEE Koon-hung | | | | |
| Mr LI Kwok-fung | | | | |
| Ms LAM Lai-fong, Fanny | | | | |
| Mr HAU Chi-keung | | | | |
| Mr YIU Ming | | | | |

| | | | | |
|----------------------------------|--|--|--|--|
| Ms OR Sin-yi, Windy | | | | |
| Mr CHAN Yung, BBS, JP | | | | |
| Mr CHAN Shung-fai | | | | |
| Mr PANG Chun-sing, George, MH | | | | |
| Mr TSANG King-chung, Kent | | | | |
| Mr WONG Wang-to | | | | |
| Mr WAN Wo-tat, Warwick | | | | |
| Mr WAN Wo-fai, MH | | | | |
| Mr YIP Yiu-shing, Chris, MH | | | | |
| Mr LLU Kwok-wah | | | | |
| Mr LAU Kwok-fan, MH | | | | |
| Mr TANG Kun-nin, Tony, MH | | | | |
| Mr LAI Sum | | | | |
| Mr LARM Wai-leung | | | | |
| Mr LAW Sai-yan | | | | |
| Mr TAM Kin-keung, Terry, MH | | | | |

| Name of Activity | “Beware of Cheating” in North District (transliteration) | Anti-Drug and Fight Crime Youth Talent Development Programme 2015 – Drama Training (transliteration) | Anti-Drug and Fight Crime Youth Talent Development Programme 2015 – Dance Practice (transliteration) | Anti-Drug and Fight Crime Youth Talent Development Programme 2015 – Musical Performance (transliteration) |
|--------------------------------------|--|---|---|--|
| Applicant Organisation(s) | Hong Kong Young Women Christian Association Ellen Li District Elderly Community Centre | ELCHK North District Youth Integrated Service Centre | ELCHK North District Youth Integrated Service Centre | ELCHK North District Youth Integrated Service Centre |
| Co-organiser(s) | - | - | - | - |
| Assisting Organiser(s) | - | - | - | - |
| Mr SO Sai-chi, SBS, MH | | | | |
| Mr HAU Kam-lam, MH, JP | | | | |
| Mr WONG Yun-keung, Simon | | | | |
| Mr LEE Koon-hung | | | | |
| Mr LI Kwok-fung | | | | |
| Ms LAM Lai-fong, Fanny | | | | |
| Mr HAU Chi-keung | | | | |
| Mr YIU Ming | | | | |
| Ms OR Sin-yi, Windy | | | | |
| Mr CHAN Yung, BBS, JP | | | | |
| Mr CHAN Shung-fai | | | | |
| Mr PANG Chun-sing, George, MH | | | | |
| Mr TSANG King-chung, Kent | | | | |
| Mr WONG Wang-to | | | | |
| Mr WAN Wo-tat, Warwick | | | | |
| Mr WAN Wo-fai, MH | | | | |
| Mr YIP Yiu-shing, Chris, MH | | | | |
| Mr LLU Kwok-wah | | | | |
| Mr LAU Kwok-fan, MH | | | | |
| Mr TANG Kun-nin, Tony, MH | | | | |
| Mr LAI Sum | | | | |
| Mr LARM Wai-leung | | | | |

| | | | | |
|--------------------------------|--|--|--|--|
| Mr LAW Sai-yan | | | | |
| Mr TAM Kin-keung, Terry, MH | | | | |

| Name of Activity | Good to Have “Teen” in Future • North District Dodgeball Open 2015 (transliteration) | Good to Have “Teen” in Future, Leap Up Tomorrow 2015 (transliteration) | Good to Have “Teen” in Future, Leap Up Tomorrow 2015 - Leap Up Training Camp for Teen (transliteration) | “Fight Crime Veterans” Scheme |
|----------------------------------|--|--|---|---|
| Applicant Organisation(s) | ELCHK North District Youth Integrated Service Centre | Jockey Club Yung Shing Lutheran Integrated Service Centre | Jockey Club Yung Shing Lutheran Integrated Service Centre | Hong Kong Evangelical Church Bradbury Sheung Shui Family Centre |
| Co-organiser(s) | - | - | - | - |
| Assisting Organiser(s) | - | - | - | - |
| Mr SO Sai-chi, SBS, MH | | | | |
| Mr HAU Kam-lam, MH, JP | | | | |
| Mr WONG Yun-keung, Simon | | | | |
| Mr LEE Koon-hung | | | | |
| Mr LI Kwok-fung | | | | |
| Ms LAM Lai-fong, Fanny | | | | |
| Mr HAU Chi-keung | | | | |
| Mr YIU Ming | | | | |
| Ms OR Sin-yi, Windy | | | | |
| Mr CHAN Yung, BBS, JP | | | | |
| Mr CHAN Shung-fai | | | | |
| Mr PANG Chun-sing, George, MH | | | | |
| Mr TSANG King-chung, Kent | | | | |
| Mr WONG Wang-to | | | | |
| Mr WAN Wo-tat, Warwick | | | | |
| Mr WAN Wo-fai, MH | | | | |
| Mr YIP Yiu-shing, Chris, MH | | | | |
| Mr LLU Kwok-wah | | | | |
| Mr LAU Kwok-fan, MH | | | | |
| Mr TANG Kun-nin, Tony, MH | | | | |
| Mr LAI Sum | | | | |
| Mr LARM Wai-leung | | | | |

| | | | | |
|--------------------------------|--|--|--|--|
| Mr LAW Sai-yan | | | | |
| Mr TAM Kin-keung, Terry, MH | | | | |

| Name of Activity | “Treasure Me” Sex Education Programme (transliteration) | Good to Have “Teen” in Future – Health 100 Programme (transliteration) | Untouchable Trap (transliteration) | Brilliant Parents 2015 - “Family• Happiness” Programme (transliteration) |
|----------------------------------|---|---|------------------------------------|--|
| Applicant Organisation(s) | The Boys & Girls Clubs Association of Hong Kong Jockey Club Fanling Children & Youth Integrated Services Centre | The Boys & Girls Clubs Association of Hong Kong Jockey Club Fanling Children & Youth Integrated Services Centre | Sunshine Lutheran Centre | Hong Kong Children & Youth Services Jockey Club Tin Ping Integrated Youth Service Centre |
| Co-organiser(s) | - | - | - | - |
| Assisting Organiser(s) | - | - | - | - |
| Mr SO Sai-chi, SBS, MH | | | | |
| Mr HAU Kam-lam, MH, JP | | | | |
| Mr WONG Yun-keung, Simon | | | | |
| Mr LEE Koon-hung | | | | |
| Mr LI Kwok-fung | | | | |
| Ms LAM Lai-fong, Fanny | | | | |
| Mr HAU Chi-keung | | | | |
| Mr YIU Ming | | | | |
| Ms OR Sin-yi, Windy | | | | |
| Mr CHAN Yung, BBS, JP | | | | |
| Mr CHAN Shung-fai | | | | |
| Mr PANG Chun-sing, George, MH | | | | |
| Mr TSANG King-chung, Kent | | | | |
| Mr WONG Wang-to | | | | |
| Mr WAN Wo-tat, Warwick | | | | |
| Mr WAN Wo-fai, MH | | | | |
| Mr YIP Yiu-shing, Chris, MH | | | | |
| Mr LLU Kwok-wah | | | | |
| Mr LAU Kwok-fan, MH | | | | |
| Mr TANG Kun-nin, Tony, MH | | | | |
| Mr LAI Sum | | | | |
| Mr LARM Wai-leung | | | | |

| | | | | |
|--------------------------------|--|--|--|--|
| Mr LAW Sai-yan | | | | |
| Mr TAM Kin-keung, Terry, MH | | | | |

| | | | | |
|----------------------------------|---|--|--|--|
| Name of Activity | ‘Good to Have “Teen” in Future’ Leap Up Life Programme (transliteration) | Production of Lunar New Year Promotion Materials | LOHAS in Autumn, Grassland Music Festival 2015 | “Change” and “Connect” the Rural and the City (transliteration) |
| Applicant Organisation(s) | Hong Kong Children & Youth Services Jockey Club Fanling Integrated Children & Youth Services Centre | North District Council Publicity Working Group | North District Office | Hong Kong Lutheran Social Service, LC-HKS Cheer Lutheran Centre |
| Co-organiser(s) | - | - | - | Jockey Club Wah Ming Lutheran Integrated Service Centre Jockey Club Yung Shing Lutheran Integrated Service Centre |
| Assisting Organiser(s) | - | - | - | - |
| Mr SO Sai-chi, SBS, MH | | | | |
| Mr HAU Kam-lam, MH, JP | | | | |
| Mr WONG Yun-keung, Simon | | | | |
| Mr LEE Koon-hung | | | | |
| Mr LI Kwok-fung | | | | |
| Ms LAM Lai-fong, Fanny | | | | |
| Mr HAU Chi-keung | | | | |
| Mr YIU Ming | | | | |
| Ms OR Sin-yi, Windy | | | | |
| Mr CHAN Yung, BBS, JP | | | | |
| Mr CHAN Shung-fai | | | | |
| Mr PANG Chun-sing, George, MH | | | | |
| Mr TSANG King-chung, Kent | | | | |
| Mr WONG Wang-to | | | | |
| Mr WAN Wo-tat, Warwick | | | | |
| Mr WAN Wo-fai, MH | | | | |
| Mr YIP Yiu-shing, Chris, MH | | | | |
| Mr LLU Kwok-wah | | | | |
| Mr LAU Kwok-fan, MH | | | | |

| | | | | |
|--------------------------------|--|--|--|--|
| Mr TANG Kun-nin, Tony, MH | | | | |
| Mr LAI Sum | | | | |
| Mr LARM Wai-leung | | | | |
| Mr LAW Sai-yan | | | | |
| Mr TAM Kin-keung, Terry, MH | | | | |

| | | | | |
|----------------------------------|---|--|---|---|
| Name of Activity | Culture and Art in North District 2015 (transliteration) | North District Best Student Election 2015-2016 | North District Recruitment and Training Expo 2016 | The 6th (2015) North District Fun Run |
| Applicant Organisation(s) | North District Arts Advancement Association Limited | North District Juvenile Association | Hong Kong Youth Power Association | North District Association for Sports And Culture Development |
| Co-organiser(s) | - | North District Secondary School Principals' Association North District Primary School Heads Association | - | - |
| Assisting Organiser(s) | - | - | - | - |
| Mr SO Sai-chi, SBS, MH | Member of North District Arts Advancement Association Limited | Honorary President of North District Juvenile Association | | |
| Mr HAU Kam-lam, MH, JP | President of North District Arts Advancement Association Limited | Honorary Vice-President of North District Juvenile Association | | |
| Mr WONG Yun-keung, Simon | | Honorary Vice-President of North District Juvenile Association | | |
| Mr LEE Koon-hung | | | | |
| Mr LI Kwok-fung | | | | |
| Ms LAM Lai-fong, Fanny | | President of North District Juvenile Association | | |
| Mr HAU Chi-keung | | | | |
| Mr YIU Ming | | Vice-Chairman of North District Juvenile Association | | |
| Ms OR Sin-yi, Windy | | Honorary Vice-President of North District Juvenile Association | | |
| Mr CHAN Yung, BBS, JP | | Honorary Vice-President of North District Juvenile Association | | |
| Mr CHAN Shung-fai | | | | |
| Mr PANG Chun-sing, George, MH | Chairman and Authorised Person of North District Arts Advancement Association Limited | Honorary Vice-President of North District Juvenile Association | | |

| | | | | |
|--------------------------------|--|--|---|---|
| Mr TSANG King-chung, Kent | | Honorary Vice-President of North District Juvenile Association | Vice-President of Hong Kong Youth Power Association | |
| Mr WONG Wang-to | | Honorary Vice-President of North District Juvenile Association | Vice-President of Hong Kong Youth Power Association | |
| Mr WAN Wo-tat, Warwick | | Honorary Vice-President of North District Juvenile Association | | |
| Mr WAN Wo-fai, MH | | Honorary Vice-President of North District Juvenile Association | | |
| Mr YIP Yiu-shing, Chris, MH | | Honorary Vice-President of North District Juvenile Association | | |
| Mr LLU Kwok-wah | | | | |
| Mr LAU Kwok-fan, MH | | Chairman and Authorised Person of North District Juvenile Association | | |
| Mr TANG Kun-nin, Tony, MH | | Honorary Vice-President of North District Juvenile Association | | |
| Mr LAI Sum | | Honorary Vice-President of North District Juvenile Association | | |
| Mr LARM Wai-leung | | Honorary Vice-President of North District Juvenile Association | | Honorary President of North District Association for Sports And Culture Development |
| Mr LAW Sai-yan | | | | |
| Mr TAM Kin-keung, Terry, MH | | | | |

| | | | |
|----------------------------------|--|--|---|
| Name of Activity | North District Tourism Promotion Programme (transliteration) | North District Tourism Promotion Week 2015 (transliteration) | North District Festival Lighting Decoration |
| Applicant Organisation(s) | Caritas Fanling Chan Chun Ha Secondary School | Hong Kong North District Flower, Bird, Insect And Fish Show Association Limited | North District Office |
| Co-organiser(s) | - | - | - |
| Assisting Organiser(s) | - | North District Women's Association Wah Do Community Service Association Fanling Residents Association | - |
| Mr SO Sai-chi, SBS, MH | | Honorary President of Hong Kong North District Flower, Bird, Insect And Fish Show Association Limited | |
| Mr HAU Kam-lam, MH, JP | | Vice-President of Hong Kong North District Flower, Bird, Insect And Fish Show Association Limited | |
| Mr WONG Yun-keung, Simon | | Honorary Consultant of Hong Kong North District Flower, Bird, Insect And Fish Show Association Limited | |
| Mr LEE Koon-hung | | | |
| Mr LI Kwok-fung | | | |
| Ms LAM Lai-fong, Fanny | | | |
| Mr HAU Chi-keung | | | |
| Mr YIU Ming | | Honorary Consultant of Hong Kong North District Flower, Bird, Insect And Fish Show Association Limited Chairman of Wah Do Community Service Association | |
| Ms OR Sin-yi, Windy | | | |
| Mr CHAN Yung, BBS, JP | | | |
| Mr CHAN Shung-fai | | | |
| Mr PANG Chun-sing, George, MH | | Member of Hong Kong North District Flower, Bird, Insect And Fish Show Association Limited | |
| Mr TSANG King-chung, Kent | | | |
| Mr WONG Wang-to | | Honorary Consultant of Hong Kong North District Flower, Bird, Insect And Fish Show Association Limited | |
| Mr WAN Wo-tat, Warwick | | | |
| Mr WAN Wo-fai, MH | | Honorary Consultant of Hong Kong North District Flower, Bird, Insect And Fish Show Association Limited | |

| | | | |
|--------------------------------|--|---|--|
| Mr YIP Yiu-shing, Chris, MH | | | |
| Mr LLU Kwok-wah | | Honorary Consultant of Hong Kong North District Flower, Bird, Insect And Fish Show Association Limited | |
| Mr LAU Kwok-fan, MH | | Honorary Consultant of Hong Kong North District Flower, Bird, Insect And Fish Show Association Limited Chairman of Fanling Residents Association | |
| Mr TANG Kun-nin, Tony, MH | | Chairman of Hong Kong North District Flower, Bird, Insect And Fish Show Association Limited | |
| Mr LAI Sum | | Honorary Consultant of Hong Kong North District Flower, Bird, Insect And Fish Show Association Limited | |
| Mr LARM Wai-leung | | Honorary Consultant of Hong Kong North District Flower, Bird, Insect And Fish Show Association Limited | |
| Mr LAW Sai-yan | | | |
| Mr TAM Kin-keung, Terry, MH | | Honorary Consultant of Hong Kong North District Flower, Bird, Insect And Fish Show Association Limited | |

Applications for North District Council Funds

The North District Council (NDC) approved 44 funding applications and an application for change of activity details of a community involvement project at the 23rd meeting as follows:

(A) Community Involvement Project

There were 38 applications for funds for community involvement projects:

| | <u>Name of Activity</u> | <u>Applicant Organisation</u> | <u>Mode of Implementation</u> | <u>District Council Funds Approved</u> |
|-----|--|--|--|--|
| (1) | North District National Day Reception in Celebration of the 66th Anniversary of the Founding of the People's Republic of China (transliteration) | North District Council Publicity Working Group | To be implemented by the working group under NDC | \$50,000 |
| (2) | North District Carnival in Celebration of the 66th National Day (transliteration) | North District Communities National Day Celebration Organizing Committee | To be implemented by the non-government organisation (NGO) | \$215,000 |
| (3) | North District Evening Party in Celebration of the 66th National Day (transliteration) | North District Communities National Day Celebration Organizing Committee | To be implemented by NGO | \$40,000 |

| | <u>Name of Activity</u> | <u>Applicant Organisation</u> | <u>Mode of Implementation</u> | <u>District Council Funds Approved</u> |
|-----|---|---|--|--|
| (4) | North District Dance Party 2015 in Celebration of the National Day (transliteration) | North District Residents Association Limited | To be implemented by NGO | \$85,000 |
| (5) | Hong Kong North District (2015) Flower Bird Insect and Fish Show | Hong Kong North District Flower, Bird, Insect And Fish Show Association Limited | To be implemented by NGO | \$1,100,000 |
| (6) | North District Youth Festival - Showing Talent with Creativity and Energy (transliteration) | North District Youth Programme Committee | To be implemented by the committee under North District Office (NDO) | \$150,000 |
| (7) | North District Fire Safety Day | Working Group on Fire Safety Activities of North District Fire Safety Committee | To be implemented by the working group under NDO | \$95,000 |
| (8) | Production of Fire Safety Promotion Materials | Working Group on Fire Safety Activities of North District Fire Safety Committee | To be implemented by the working group under NDO | \$55,000 |

| | <u>Name of Activity</u> | <u>Applicant Organisation</u> | <u>Mode of Implementation</u> | <u>District Council Funds Approved</u> |
|------|--|---|--|--|
| (9) | Open Day for Fanling Fire Station cum Fanling Ambulance Depot | Working Group on Fire Safety Activities of North District Fire Safety Committee | To be implemented by the working group under NDO | \$33,500 |
| (10) | Fire Safety Competition | Working Group on Fire Safety Activities of North District Fire Safety Committee | To be implemented by the working group under NDO | \$8,000 |
| (11) | Promotion Activities of Prevention of Hill Fires | Working Group on Fire Safety Activities of North District Fire Safety Committee | To be implemented by the working group under NDO | \$18,500 |
| (12) | Young People@NICE! (transliteration) | North District Civic Education Committee | To be implemented by the committee under NDO | \$126,689 |
| (13) | North District Community Participation Scheme for Youth 2015 (transliteration) | North District Civic Education Committee | To be implemented by the committee under NDO | \$123,311 |
| (14) | North District Anti-drug and Fight Crime Variety Show 2015 (transliteration) | North District Fight Crime Committee | To be implemented by the committee under NDO | \$752,000 |

| | <u>Name of Activity</u> | <u>Applicant Organisation</u> | <u>Mode of Implementation</u> | <u>District Council Funds Approved</u> |
|------|---|--|--|--|
| (15) | Senior Police Call Scheme | Hong Kong Police Force Border District | To be implemented by government department | \$19,800 |
| (16) | Tai Po District School Fight Crime Scheme 2015 – Generation Y Scheme (transliteration) | Hong Kong Police Force Tai Po District | To be implemented by government department | \$30,000 |
| (17) | “Beware of Cheating” in North District (transliteration) | Hong Kong Young Women Christian Association Ellen Li District Elderly Community Centre | To be implemented by NGO | \$20,000 |
| (18) | Anti-Drug and Fight Crime Youth Talent Development Programme 2015 – Drama Training (transliteration) | ELCHK North District Integrated Service Centre | To be implemented by NGO | \$5,700 |
| (19) | Anti-Drug and Fight Crime Youth Talent Development Programme 2015 – Dance Practice (transliteration) | ELCHK North District Integrated Service Centre | To be implemented by NGO | \$18,540 |

| | <u>Name of Activity</u> | <u>Applicant Organisation</u> | <u>Mode of Implementation</u> | <u>District Council Funds Approved</u> |
|------|---|--|-------------------------------|--|
| (20) | Anti-Drug and Fight Crime Youth Talent Development Programme 2015 – Musical Performance (transliteration) | ELCHK North Youth Service Integrated Centre | To be implemented by NGO | \$15,760 |
| (21) | Good to Have “Teen” in Future • North District Dodgeball Open 2015 (transliteration) | ELCHK North Youth Service Integrated Centre | To be implemented by NGO | \$40,000 |
| (22) | Good to Have “Teen” in Future, Leap Up Tomorrow 2015 (transliteration) | Jockey Club Yung Shing Lutheran Service Integrated Centre | To be implemented by NGO | \$28,000 |
| (23) | Good to Have “Teen” in Future, Leap Up Tomorrow 2015 - Leap Up Training Camp for Teen (transliteration) | Jockey Club Yung Shing Lutheran Service Integrated Centre | To be implemented by NGO | \$12,000 |
| (24) | “Fight Crime Veterans” Scheme | Hong Kong Evangelical Church Bradbury Sheung Shui Family Centre | To be implemented by NGO | \$20,300 |
| (25) | “Treasure Me” Sex Education Programme (transliteration) | The Boys & Girls Clubs Association of Hong Kong Jockey Club Fanling Children & Youth Integrated Services | To be implemented by NGO | \$22,000 |

| <u>Name of Activity</u> | <u>Applicant Organisation</u> Centre | <u>Mode of Implementation</u> | <u>District Council Funds Approved</u> |
|---|---|--|--|
| (26) Good to Have “Teen” in Future – Health 100 Programme (transliteration) | The Boys & Girls Clubs Association of Hong Kong Jockey Club Fanling Children & Youth Integrated Services Centre | To be implemented by NGO | \$40,000 |
| (27) Untouchable Trap (transliteration) | Sunshine Lutheran Centre | To be implemented by NGO | \$18,806 |
| (28) Brilliant Parents 2015 - “Family Happiness” Programme (transliteration) | Hong Kong Children & Youth Services Jockey Club Tin Ping Integrated Youth Service Centre | To be implemented by NGO | \$22,000 |
| (29) ‘Good to Have “Teen” in Future’ Leap Up Life Programme (transliteration) | Hong Kong Children & Youth Services Jockey Club Fanling Integrated Children & Youth Services Centre | To be implemented by NGO | \$27,200 |
| (30) Production of Lunar New Year Promotion Materials | North District Council Publicity Working Group | To be implemented by the working group under NDC | \$110,100 |

| | <u>Name of Activity</u> | <u>Applicant Organisation</u> | <u>Mode of Implementation</u> | <u>District Council Funds Approved</u> |
|------|---|---|--|--|
| (31) | LOHAS in Autumn, Grassland Music Festival 2015 | North District Office | To be implemented by government department | \$760,000 |
| (32) | “Change” and “Connect” the Rural and the City (transliteration) | Hong Kong Lutheran Social Service, LC-HKS Cheer Lutheran Centre | To be implemented by NGO | \$157,000 |
| (33) | Culture and Art in North District 2015 (transliteration) | North District Arts Advancement Association Limited | To be implemented by NGO | \$633,550 |
| (34) | North District Best Student Election 2015-2016 | North District Juvenile Association | To be implemented by NGO | \$160,000 |
| (35) | North District Recruitment and Training Expo 2016 | Hong Kong Youth Power Association | To be implemented by NGO | \$145,000 |
| (36) | The 6th (2015) North District Fun Run | North District Association for Sports And Culture Development | To be implemented by NGO | \$401,500 |
| (37) | North District Tourism Promotion Programme (transliteration) | Caritas Fanling Chan Chun Ha Secondary School | To be implemented by NGO | \$74,300 |

| | <u>Name of Activity</u> | <u>Applicant Organisation</u> | <u>Mode of Implementation</u> | <u>District Council Funds Approved</u> |
|------|--|---|-------------------------------|--|
| (38) | North District Tourism Promotion Week 2015 (transliteration) | Hong Kong North District Flower, Bird, Insect And Fish Show Association Limited | To be implemented by NGO | \$93,400 |

(B) District Minor Works Project

There were 5 applications for District Minor Works Project funds

| | <u>Title of Works</u> | <u>Department / Organisation</u> | <u>Mode of Implementation</u> | <u>District Council Funds Approved</u> |
|-----|---|--|-------------------------------|--|
| (1) | Provision of Lockers at Fanling Recreation Ground | District Facilities Management Committee | District Minor Works Project | \$120,000 |
| (2) | Landscaping of the Government Land between Buddhist Po Ching Home for the Aged Women and Parkford Garden at Chi Fuk Circuit | District Facilities Management Committee | District Minor Works Project | \$200,000 |
| (3) | Improvements to Sheung Shui Wa Shan Sitting-out Area | Leisure and Cultural Services Department | District Minor Works Project | \$1,400,000 |
| (4) | Improvements to Sheung Shan Kai Wat Sitting-out Area | Leisure and Cultural Services Department | District Minor Works Project | \$110,000 |

| | <u>Title of Works</u> | <u>Department / Organisation</u> | <u>Mode of Implementation</u> | <u>District Council Funds Approved</u> |
|-----|---|--|-------------------------------|--|
| (5) | Installation of Temporary Chemical Dosing Tank at Fanling Swimming Pool | Leisure and Cultural Services Department | District Minor Works Project | \$66,000 |

There was an application for revised funding for a district minor works project:

| | <u>Title of Works</u> | <u>Department / Organisation</u> | <u>Mode of Implementation</u> | <u>Revised District Council Funds Approved</u> |
|-----|---|--|-------------------------------|--|
| (1) | Provision of Toilets and Changing Rooms at Luen Wo Hui Playground (ND-DMW119) | District Facilities Management Committee | District Minor Works Project | \$4,970,000 |

(C) Application for Change of Activity Details

There was an application for change of activity details of a community involvement project:

| | <u>Activity/Programme</u> | <u>Original Organiser</u> | <u>Revised Organiser</u> |
|-----|---|--------------------------------------|--------------------------|
| (1) | North District Festival Lighting Decoration | Working Group on Festival Activities | NDO |